

SC Series Attachment

SC Series

Plate model	Applicable to model	Note
F-SCD-1	SCDA10000T-48	For 19-inch rack (bracket type)
F-SCD-2	SCDA10000T-48	For 19-inch rack

Example of installation

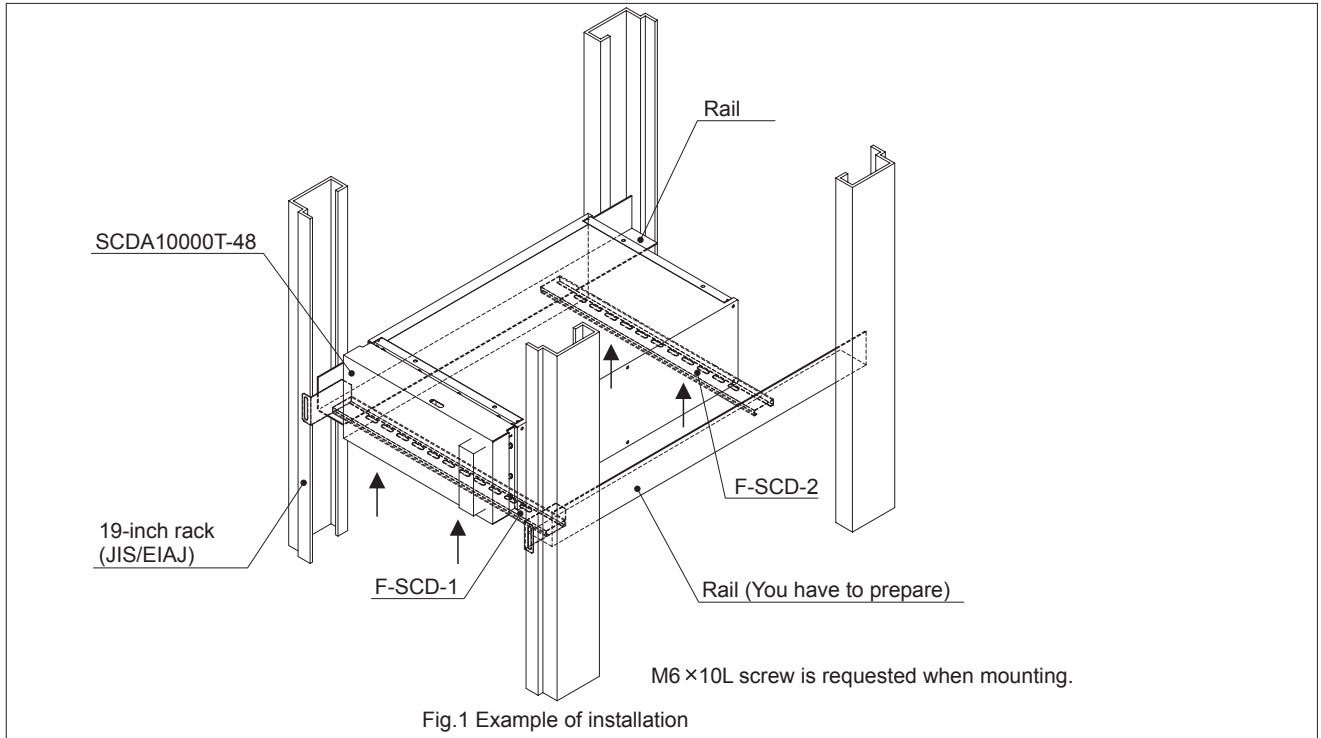

External view

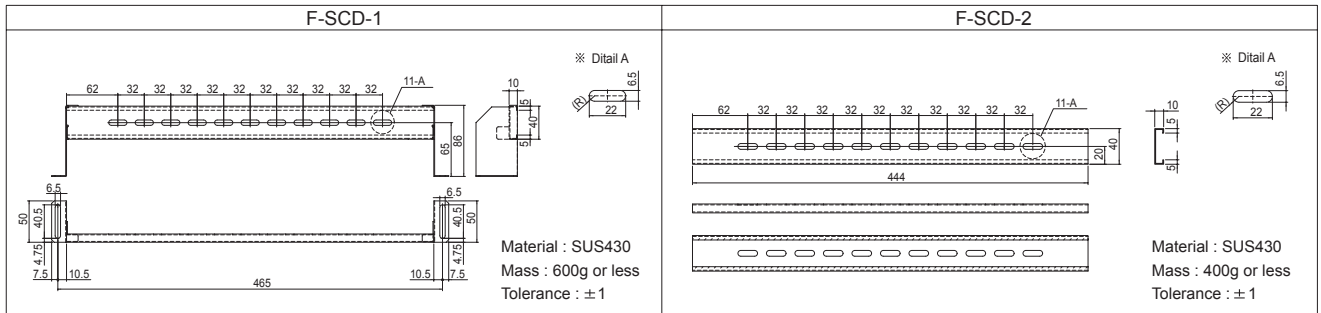

Mounting position

4 mounting position is available.
Mounting position and space distance a are on Table 1.

Table 1 position and space distance (mm)

Position	Distance a
A	115-118
B	83-93
C	51-61
D	19-29

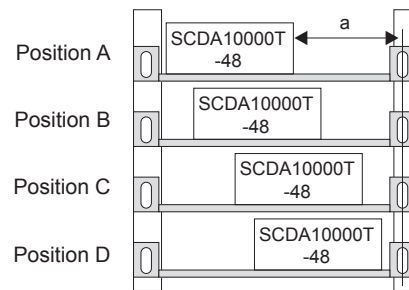

Front View

Others

- 19-inch rails are required for initial preparation.
- 2 units or more stack is not recommended mounting with F-SCD-1 and F-SCD-2.