

■ PB · PMA Series Attachment

BASE Attachment

Plate model	Applicable models
F-PBA10-1	PBA10F
F-PBA15-1	PBA15F, PBW15F
F-PBA30-1	PBA30F, PBW30F, PMA15F
F-PBA50-1	PBA50F, PBW50F, PMA30F
F-PBA75-1	PBA75F, PMA60F
F-PBA100-1	PBA100F
F-PBA150-1	PBA150F, PMA100F

Example

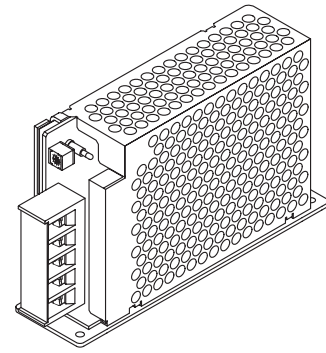

< TOP VIEW > (Unit : mm) (Tolerance : ±1)

<p>F-PBA10-1</p> <p>Size</p> <ul style="list-style-type: none"> * Material : SECC * Thickness : 2.0 * Weight : 60g max 	<p>F-PBA15-1</p> <p>Size</p> <ul style="list-style-type: none"> * Material : SECC * Thickness : 2.0 * Weight : 70g max
<p>* M3 Flat screw is requested when mounting. Please check the instruction manual for the size of screw.</p>	
<p>Mounting hole size</p> <p>FRONT ←</p>	<p>Mounting hole size</p> <p>FRONT ←</p>
<p>F-PBA30-1</p> <p>Size</p> <ul style="list-style-type: none"> * Material : SECC * Thickness : 2.0 * Weight : 85g max 	<p>F-PBA50-1</p> <p>Size</p> <ul style="list-style-type: none"> * Material : SECC * Thickness : 2.0 * Weight : 95g max
<p>* M3 Flat screw is requested when mounting. Please check the instruction manual for the size of screw.</p>	
<p>Mounting hole size</p> <p>FRONT ←</p>	<p>Mounting hole size</p> <p>FRONT ←</p>

< TOP VIEW > (Unit : mm) (Tolerance : ±1)

<p style="text-align: center;">F-PBA75-1</p> <p>Size</p> <ul style="list-style-type: none"> * Material : SECC * Thickness : 2.0 * Weight : 110g max 	<p style="text-align: center;">F-PBA100-1</p> <p>Size</p> <ul style="list-style-type: none"> * Material : SECC * Thickness : 2.0 * Weight : 110g max
<p>* M3 Flat screw is requested when mounting. Please check the instruction manual for the size of screw.</p>	
<p>Mounting hole size</p> <p>FRONT ←</p>	<p>Mounting hole size</p> <p>FRONT ←</p>
<p style="text-align: center;">F-PBA150-1</p>	
<p>Size</p> <ul style="list-style-type: none"> * Material : SECC * Thickness : 2.0 * Weight : 130g max 	
<p>* M3 Flat screw is requested when mounting. Please check the instruction manual for the size of screw.</p>	
<p>Mounting hole size</p> <p>FRONT ←</p>	

FRONT · REVERSE
Attachment

Plate model	Applicable models
F-PBA10-2	PBA10F
F-PBA15-2	PBA15F, PBW15F
F-PBA30-2	PBA30F, PBW30F, PMA15F
F-PBA50-2	PBA50F, PBW50F, PMA30F
F-PBA75-2	PBA75F, PMA60F
F-PBA100-2	PBA100F
F-PBA150-2	PBA150F, PMA100F

Example

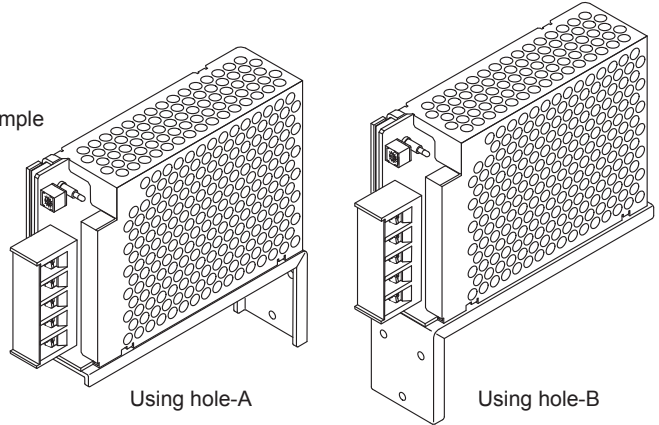

Using hole-A

Using hole-B

< TOP VIEW > (Unit : mm) (Tolerance : ±1)

F-PBA10-2	F-PBA15-2
<p>Size</p> <ul style="list-style-type: none"> * Material : SECC * Thickness : 1.6 * Weight : 60g max 	<p>Size</p> <ul style="list-style-type: none"> * Material : SECC * Thickness : 1.6 * Weight : 70g max
<p>* M3 screw is requested when mounting. Please check the instruction manual for the size of screw.</p>	
F-PBA30-2	F-PBA50-2
<p>Size</p> <ul style="list-style-type: none"> * Material : SECC * Thickness : 1.6 * Weight : 80g max 	<p>Size</p> <ul style="list-style-type: none"> * Material : SECC * Thickness : 2.0 * Weight : 120g max
<p>* M3 screw is requested when mounting. Please check the instruction manual for the size of screw.</p>	

< TOP VIEW > (Unit : mm) (Tolerance : ±1)

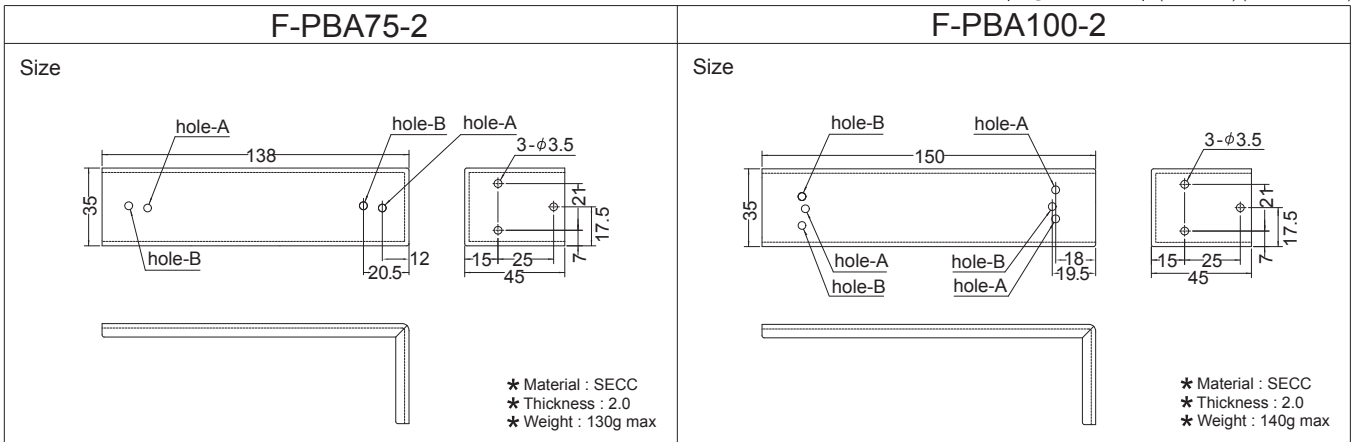

★ M3 screw is requested when mounting.
Please check the instruction manual for the size of screw.

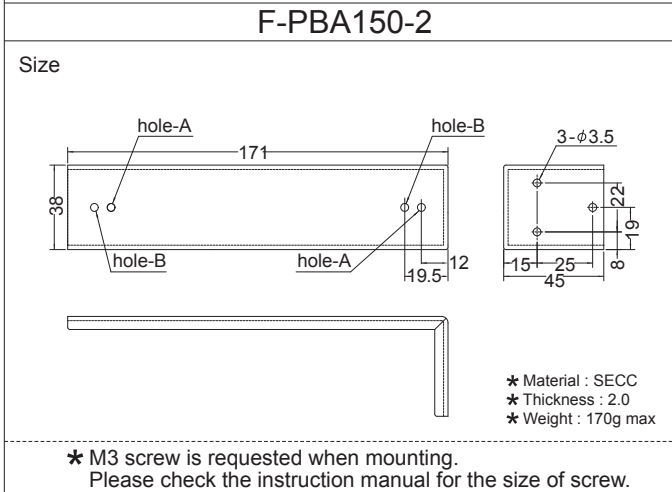

★ M3 screw is requested when mounting.
Please check the instruction manual for the size of screw.

PLA · PJA Series Attachment

BASE Attachment

Plate model	Applicable models
F-PLA15-1	PLA15F
F-PLA30-1	PLA30F
F-PLA50-1	PLA50F
F-PLA100-1	PJA100F, PJA150F
F-PLA300-1	PJA300F
F-PLA600-1	PJA600F

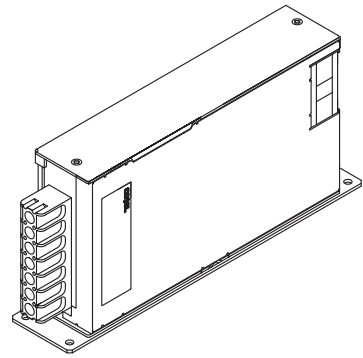

Example (PJA300F)

< TOP VIEW > (Unit : mm) (Tolerance : ±1)

<p>F-PLA15-1</p> <ul style="list-style-type: none"> * Material : SECC * Thickness : 2.0 * Weight : 65g max 	<p>F-PLA30-1</p> <ul style="list-style-type: none"> * Material : SECC * Thickness : 2.0 * Weight : 75g max
<p>* M3 Flat screw is requested when mounting. Please check the instruction manual for the size of screw.</p>	
<p>Mounting hole size</p> <p>FRONT ←</p>	<p>Mounting hole size</p> <p>FRONT ←</p>
<p>F-PLA50-1</p> <ul style="list-style-type: none"> * Material : SECC * Thickness : 2.0 * Weight : 85g max 	<p>F-PLA100-1</p> <ul style="list-style-type: none"> * Material : SEHC * Thickness : 2.3 * hole-A : PJA100F * hole-B : PJA150F * Weight : 130g max
<p>* M3 Flat screw is requested when mounting. Please check the instruction manual for the size of screw.</p>	
<p>Mounting hole size</p> <p>FRONT ←</p>	<p>Mounting hole size</p> <p>FRONT ←</p>

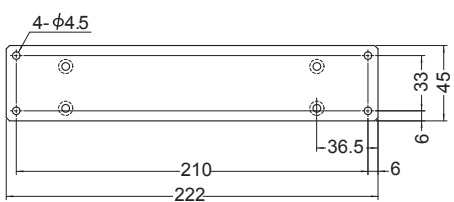
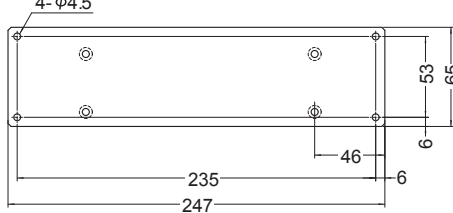
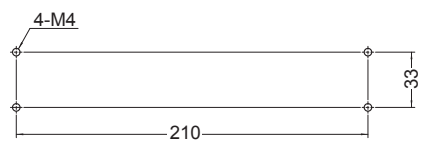
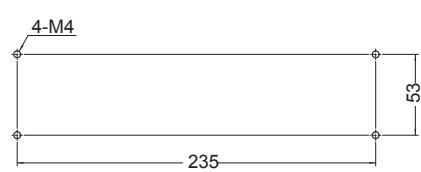
F-PLA300-1	F-PLA600-1
<p>Size</p>  <ul style="list-style-type: none"> * Material : SEHC * Thickness : 3.2 * Weight : 300g max 	<p>Size</p>  <ul style="list-style-type: none"> * Material : SEHC * Thickness : 3.2 * Weight : 460g max
<p style="text-align: center;">* M4 Flat screw is requested when mounting. Please check the instruction manual for the size of screw.</p>	
<p>Mounting hole size</p> <p>FRONT ←</p> 	<p>Mounting hole size</p> <p>FRONT ←</p> 

FRONT · REVERSE Attachment

Plate model	Applicable models
F-PLA15-2	PLA15F
F-PLA30-2	PLA30F
F-PLA50-2	PLA50F
F-PLA100-2	PJA100F, PJA150F
F-PLA300-2	PJA300F
F-PLA600-2	PJA600F

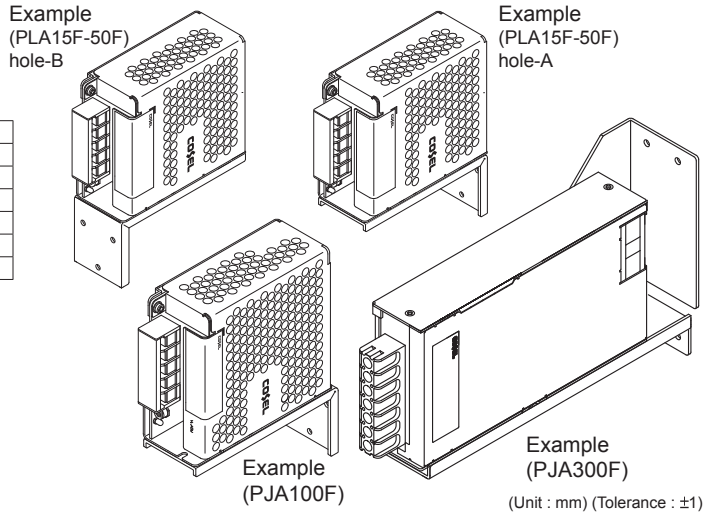

F-PLA15-2	F-PLA30-2
<p>Size</p> <p>★ Material : SECC ★ Thickness : 1.6 ★ Weight : 70g max</p>	<p>Size</p> <p>★ Material : SECC ★ Thickness : 1.6 ★ Weight : 80g max</p>
<p>★ M3 screw is requested when mounting. Please check the instruction manual for the size of screw.</p>	
F-PLA50-2	F-PLA100-2
<p>Size</p> <p>★ Material : SECC ★ Thickness : 1.6 ★ Weight : 85g max</p>	<p>Size</p> <p>★ Material : SECC ★ Thickness : 2.0 ★ hole-A : PJA100F ★ hole-B : PJA150F ★ Weight : 120g max</p>
<p>★ M3 screw is requested when mounting. Please check the instruction manual for the size of screw.</p>	

(Unit : mm) (Tolerance : ±1)

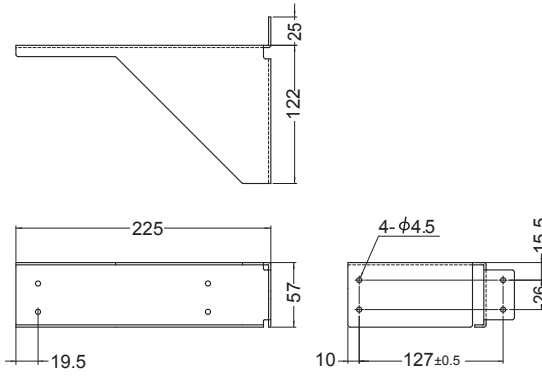
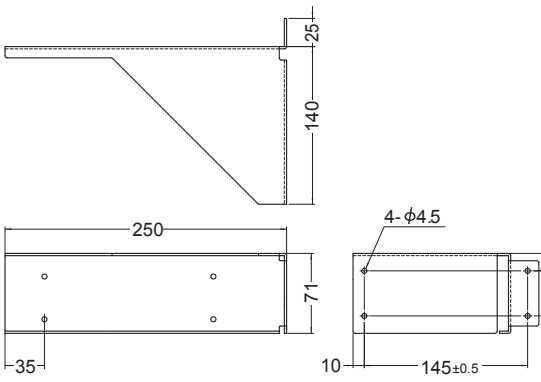
F-PLA300-2	F-PLA600-2
<p>Size</p>  <ul style="list-style-type: none"> * Material : SEHC * Thickness : 2.0 * Weight : 600g max 	<p>Size</p>  <ul style="list-style-type: none"> * Material : SEHC * Thickness : 2.0 * Weight : 800g max
<p>* M4 screw is requested when mounting. Please check the instruction manual for the size of screw.</p>	

BASE Attachment

Plate model	Applicable models
F-PLA300-3	PJA300F
F-PLA600-3	PJA600F

Example
(PJA300F)

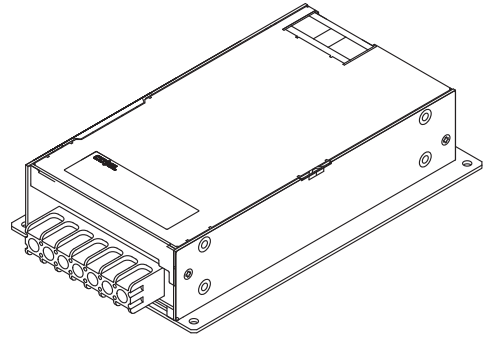

< TOP VIEW > (Unit : mm) (Tolerance : ±1)

F-PLA300-3		F-PLA600-3	
Size	<ul style="list-style-type: none"> * Material : SEHC * Thickness : 3.2 * Weight : 750g max 	Size	<ul style="list-style-type: none"> * Material : SEHC * Thickness : 3.2 * Weight : 950g max
<p>* M4 Flat screw is requested when mounting. Please check the instruction manual for the size of screw.</p>			
Mounting hole size	<p>FRONT ←</p>	Mounting hole size	<p>FRONT ←</p>