

**TSC-400-000/TSC-600-000**

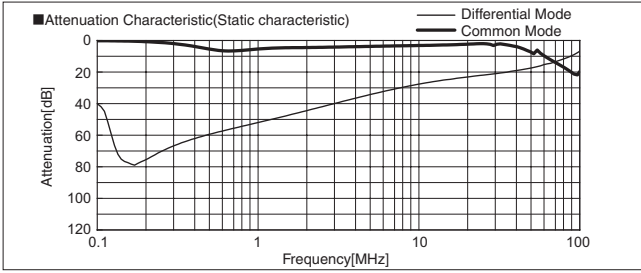

**TSC-400-304/TSC-600-304**

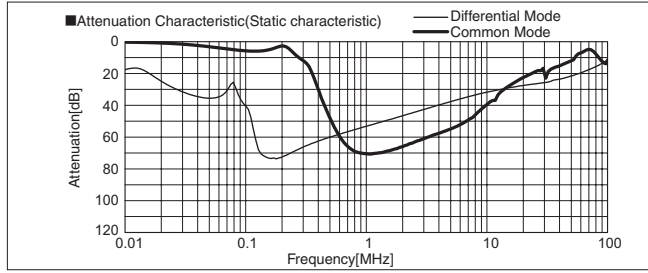

**TSC-400-664/TSC-600-664**

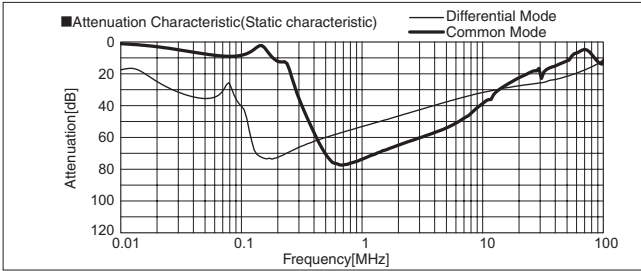

**TSC-400-665/TSC-600-665**

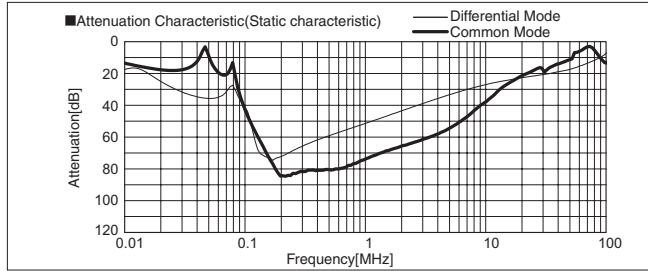

**TSC-400-000-H/TSC-600-000-H**

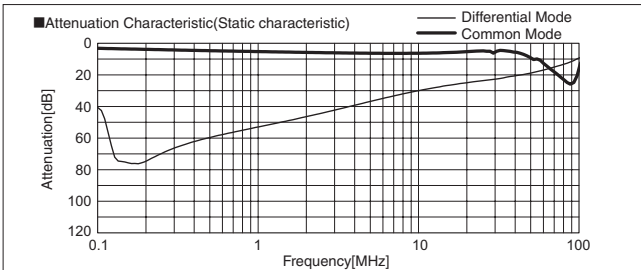

**TSC-400-304-H/TSC-600-304-H**

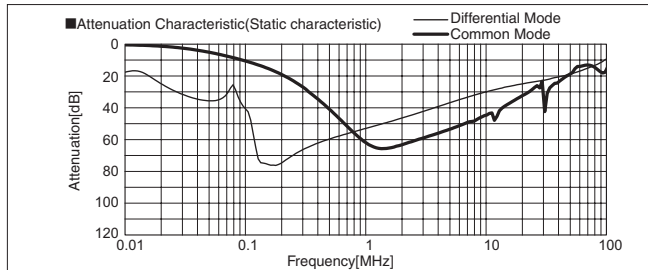

**TSC-400-664-H/TSC-600-664-H**

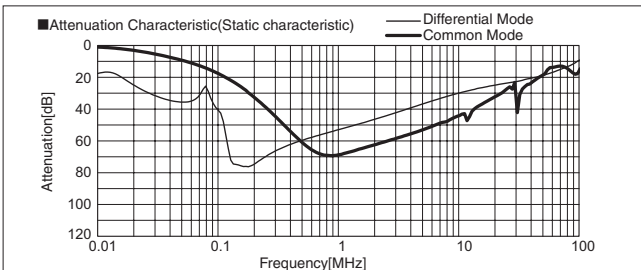

**TSC-400-665-H/TSC-600-665-H**

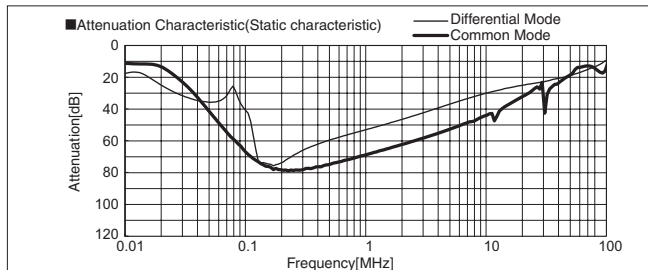

**TSD-400-105/TSD-600-105**

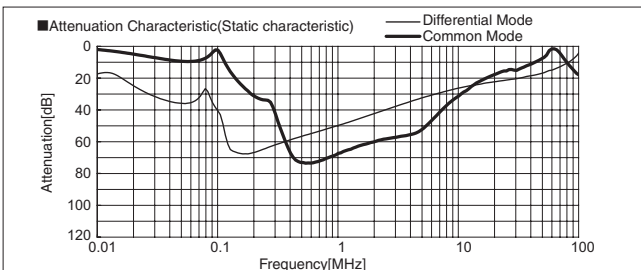

**TSD-400-215/TSD-600-215**

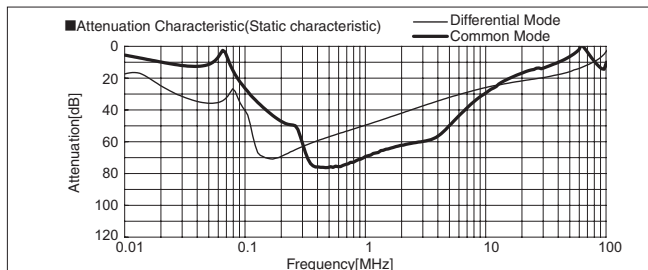

**TSD-400-136/TSD-600-136**

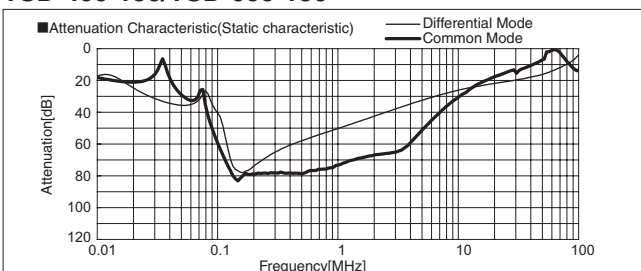

**TSD-400-186/TSD-600-186**

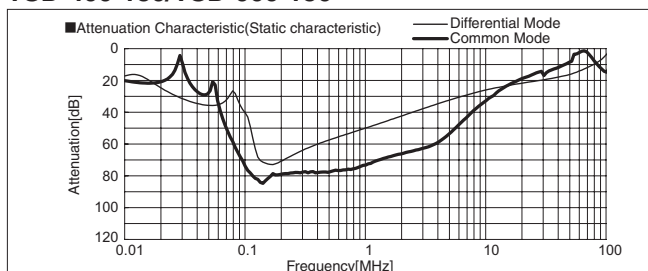

# 1 Busbar Applicable connect

■ When wiring an M10 terminal to the busbar, the external dimension of the crimp terminal is critical in maintaining isolation distance between insulating resin, chassis, and mounting screws. We therefore recommend that you use terminals of the dimensions shown in table 1.1.

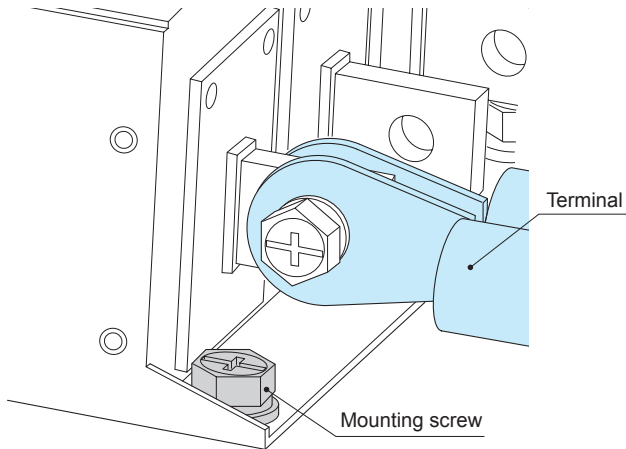

Fig.1.1 Busbar connection

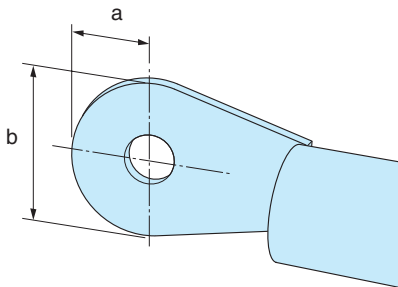

Fig.1.2 Terminals dimension

table.1.1 Selected conditions terminals dimension

Model Name	"a"Allowable dimension	"b"Allowable dimension
TSC/TSD series	19.5mm max	38.5mm max

# 2 Notes on wiring and storage

- Notes on wiring  
 Since the (copper) busbar has not been surface treated, surface oxidation may form a resistive layer between the contacts. We therefore recommend abrasion of all mating surfaces before, and wearing gloves during, all wiring work. Please be careful not to leave fingerprints.
- Notes on storage  
 Please avoid storage in environments where copper corrosion is concerned. Storage under a normal temperature and humidity environment is recommended.

## 1 Method of connecting EMI/EMC Filter

### (1) Single Phase

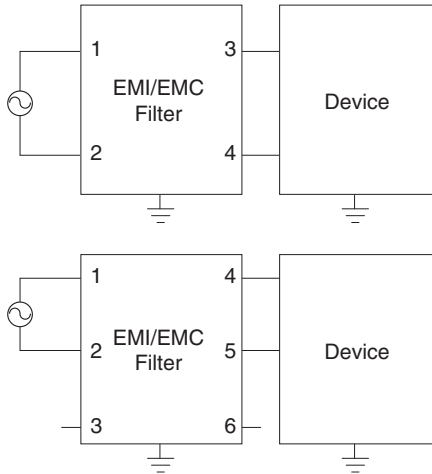

※Three phase EMI/EMC filter is also available as a single phase input type.

### (2) Three phase (Delta-connection)

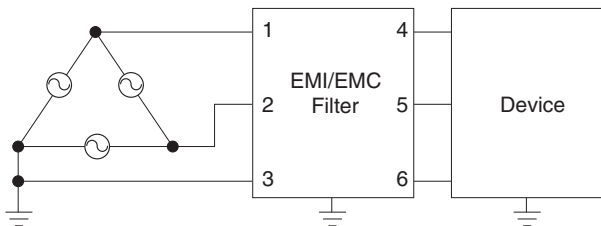

### (3) Three phase (Star-connection)

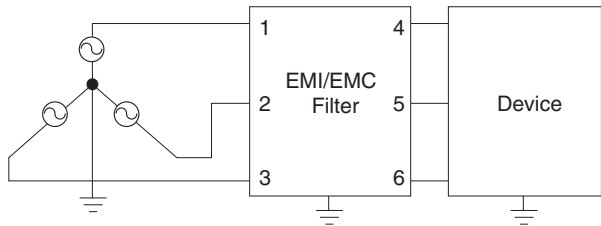

[Reference] Example of calculating input current calculation

Input voltage 400 [V]

Input capacity of the equipment 4000 [VA]

$$\text{Input current} = \frac{4000 \text{ [VA]}}{400 \text{ [V]} \times \sqrt{3}} = 5.8 \text{ [A]}$$

## 2 Caution when connecting EMI/EMC Filter

Please note the excessive temperature increase of EMI/EMC filter. Please contact us if judgement is difficult.

### (1) Input voltage and frequency

Please use within the rated voltage (or maximum voltage) of each model.

Input frequency specification for AC input EMI/EMC filter is considered as commercial frequency (50/60Hz).

It should not be used under the following conditions.

- 1) Distorted input voltage waveform.  
(Triangle wave, square wave etc.)
- 2) High input frequency (ex: 400Hz)

### (2) Input current

Please use within the rated current of each model.

EMI/EMC filters have short term peak current capability. Therefore, it can flow ~40A or ten times of rated current, non-repeated, within a few ms such as inrush current of power supply etc.

However, it should not be used under the following conditions.

- 1) Long duration peak current.
- 2) Peak current or high-frequency current is continuously flowing.

### (3) Connection to a general-purpose inverter (servo driver)

Please connect EMI/EMC filter to input side of inverter driver (servo driver).

It should not be used between the inverter (servo driver) and the motor.

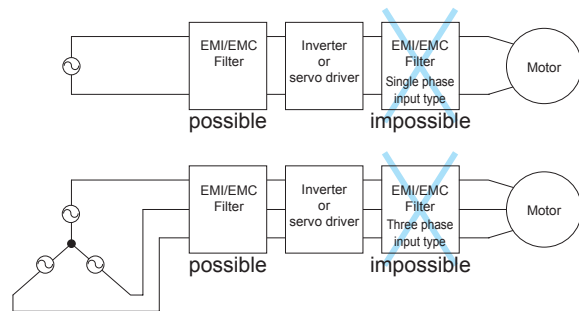

## 3 Safety Considerations

- To apply for safety standard approval using this EMI/EMC Filter, the following conditions must be met.
- The unit must be used as a component of an end-use equipment.
- Protection earth terminal (PE) must be connected to safety ground of end-use equipment.

### (1) Attenuation Characteristic(Static characteristic)

※ Attenuation=  $20\log(U_{b1}/U_{b2})$ (dB)  
 $U_{b1}$ : Voltage in state without filters  
 $U_{b2}$ : Voltage in state which added filters  
 ※ N.A.: Network analyzer

■ Object product : Single phase input type (Differential mode)

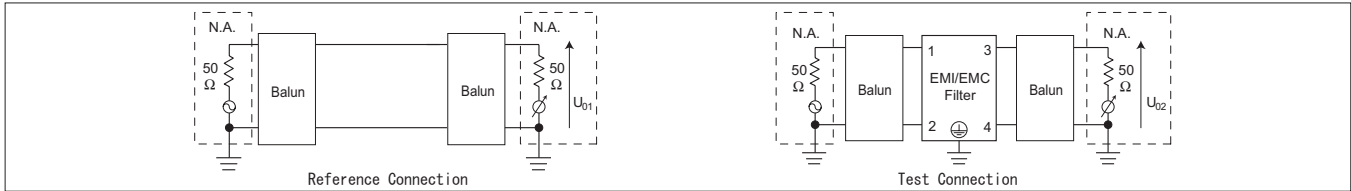

■ Object product : Single phase input type (Common mode)

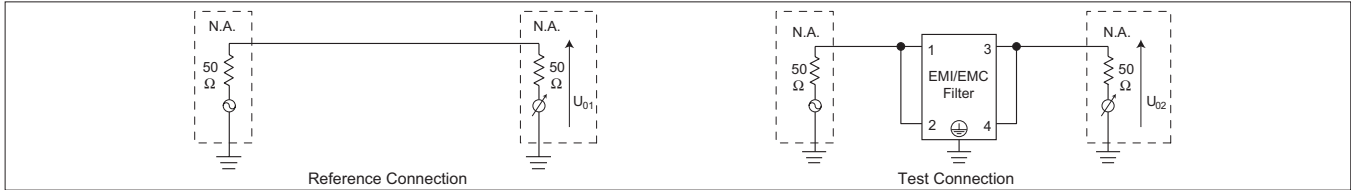

■ Object product : Three phase input type (Differential mode)

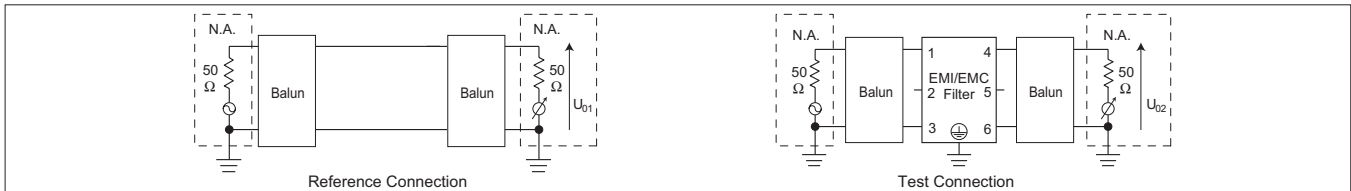

■ Object product : Three phase input type (Common mode)

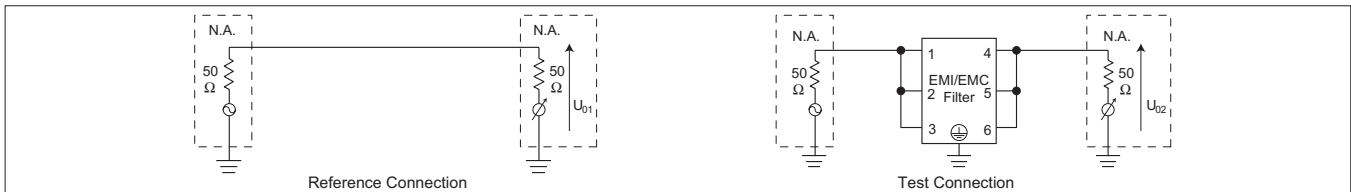

■ Object product : DC input type (Differential mode)

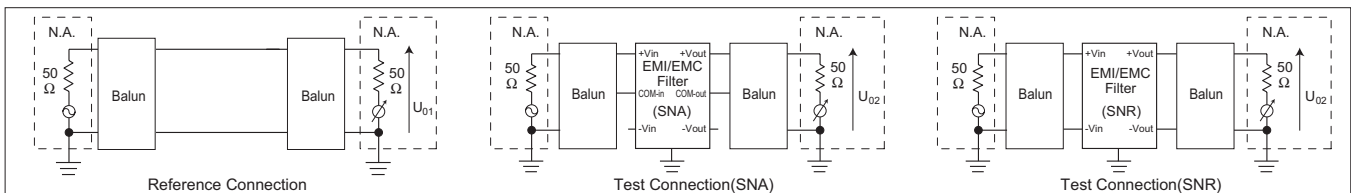

■ Object product : DC input type (Common mode)

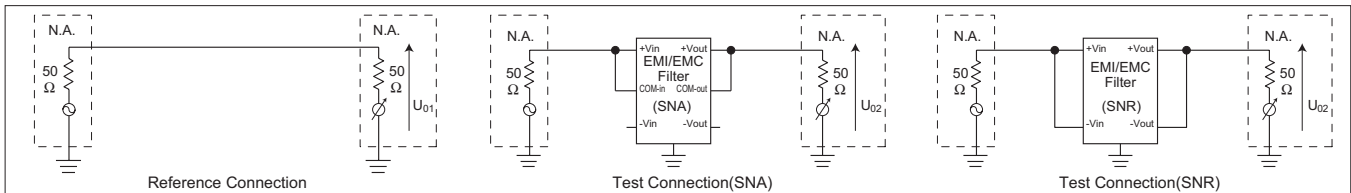

### (2) Pulse Attenuation Characteristic

