

Basic Characteristics Data

Model	Circuit method	Switching frequency [kHz]	Input current [A]	Rated input fuse	Inrush current protection circuit	PCB/Pattern			Series/Parallel operation availability	
						Material	Single sided	Double sided	Series operation	Parallel operation
SNDBS400B	Forward converter	370	1.72 *1	450V 5A	-	FR-4		Yes	Yes	Yes *2
SNDBS700B	Forward converter	381	2.76 *1	450V 10A	-	FR-4		Yes	Yes	Yes *2

*1 Refer to specification.

*2 Refer to Instruction Manual.

1	Terminal Connection	SNDBS-8
2	Connection for Standard Use	SNDBS-8
3	Wiring Input / Output Terminal	SNDBS-9
3.1	Wiring input terminal	SNDBS-9
3.2	Wiring output terminal	SNDBS-9
4	Function	SNDBS-10
4.1	Overcurrent protection	SNDBS-10
4.2	Overvoltage protection	SNDBS-10
4.3	Thermal detection / Thermal protection	SNDBS-10
4.4	Inverter operation monitor (IOG)	SNDBS-10
4.5	Enable signal (ENA)	SNDBS-10
4.6	Remote ON / OFF (RC2)	SNDBS-11
4.7	Remote sensing	SNDBS-11
4.8	Output voltage adjusting	SNDBS-11
4.9	Isolation	SNDBS-11
5	Series and Parallel operation	SNDBS-12
5.1	Series operation	SNDBS-12
5.2	Parallel operation / Master-slave operation	SNDBS-12
5.3	N+1 Redundancy operation	SNDBS-12
6	Implementation · Mounting Method	SNDBS-13
6.1	Mounting method	SNDBS-13
6.2	Derating	SNDBS-13

1 Terminal Connection

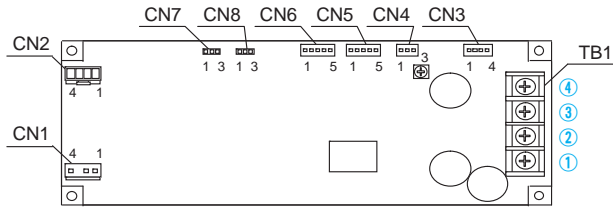

Table 1.1 Terminal connection and functions

No	Terminal connection	Function
①②	+VOUT	+DC output
③④	-VOUT	-DC output

Table 1.2 Configuration and functions of CN1 and CN2

Pin No.	Function
1	ENA-B : Enable signal
2	-VIN : -DC input
3	NC : No connection
4	+VIN : +DC input

Housing for protection is attached on CN2 at shipping from factory

Table 1.3 Configuration and functions of CN3

Pin No.	Function
1	+M : +Self sensing terminal. (Do not wire for external connection.)
2	+S : +Remote sensing
3	-S : -Remote sensing
4	-M : -Self sensing terminal. (Do not wire for external connection.)

Short-pieces for without remote sensing is attached on CN3 at shipping from factory

Table 1.4 Terminal connection and functions CN4

Pin No.	Function
1	RC2 : Remote ON/OFF
2	TEMP : Thermal detection / Thermal protection
3	IOG : Inverter operation monitor

Table 1.5 Terminal connection and functions of CN5 and CN6

Pin No.	Function
1	+S : +Remote sensing
2	-S : -Remote sensing
3	TRM : Adjustment of output voltage
4	VB : Voltage balance
5	CB : Current balance

Common signs among CN4 and CN5 represent the same potential.

Table 1.6 Terminal connection and functions of CN7

Pin No.	Function	
1	Setting of ENA	Set short-piece to 1 and 2 with SNDPF1000
2		Set short-piece to 2 and 3 with SNDPG750

Short-piece for setting is attached on CN7 at shipping from factory

Table 1.7 Terminal connection and functions of CN8

Pin No.	Function	
1	Setting of ENA effective	Set short-piece to 1 and 2 when ENA is Enable (at shipping from factory)
2		Set short-piece to 2 and 3 when ENA is Disable

Short-piece for setting is attached on CN8 at shipping from factory

Table 1.8 Mating connectors and terminals of CN1, CN2, CN3, CN4, CN5 and CN6

Connector	Mating connector	Terminal	Mfr.	
CN1 CN2	B3P4-VH-B	VHR-4N	Reel :SVH-21T-P1.1 Loose:BVH-21T-P1.1	J.S.T.
CN3	B4B-XH-AM	XHP-4	Reel :SXH-001T-P0.6 Loose:BXH-001T-P0.6	
CN4	B3B-XH-AM	XHP-3	Reel :SXH-001T-P0.6 Loose:BXH-001T-P0.6	
CN5 CN6	B5B-XH-AM	XHP-5	Reel :SXH-001T-P0.6 Loose:BXH-001T-P0.6	

2 Connection for Standard Use

■ In order to use the power supply, it is necessary Fig.2.1.

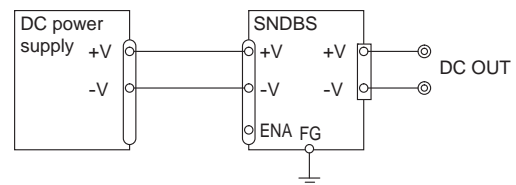

* Set short-piece to 2 and 3 on CN8

(a) Connection for DC input

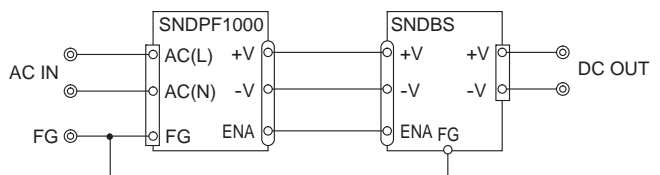

* Set short-piece to 1 and 2 on CN7 for using with SNDPF1000

* Set short-piece to 2 and 3 on CN7 for using with SNDPG750

* Refer to 4.5 Enable (ENA)

(b) Connection for AC input

Fig.2.1 Connection for Standard Use

■ The SNDBS Series handles only the DC input.
Avoid applying AC input directly.
It will damage the power supply.

- Between the same terminal name, CN2 CN1 are power supply are connected internally. Be used in multiple units can be cascaded. Keep drawing current per pin below 7A for CN1/CN2.
- Operate with the conduction cooling(e.g. heat radiation from the aluminum base plate to the attached heat sink). Reference: 6.2 "Derating"
- Please contact us If you need except SNDPG750/SNDPF1000 for the input .

3 Wiring Input / Output Terminal

3.1 Wiring input terminal

(1) External capacitor on the Input side

- When it turns on an input with a switch directly, one several times the surge voltage of input voltage occurs by the inductance ingredient of an input line, and there is a possibility that a power supply may break down.

Please install a capacitor between +VIN and -VIN input terminals and absorb surge.

Capacitor : 47 μ F or more

- When the line impedance is high or the input voltage rise quickly at start-up (less than 10 μ s), install a capacitor between +VIN and -VIN input terminals.
- Install a correspondence filter, if a noise standard meeting is required or if the surge voltage may be applied to the unit. Please contact us in details.

(2) Input voltage rang/Input current range

- The specification of input ripple voltage is 40Vp-p.
- Make sure that the voltage fluctuation, including the ripple voltage, will not exceed the input voltage range.
- Use a front end unit with enough power, considering the start-up current I_p of this unit.

(3) Operation with AC input

- The SNDBS series handles only for the DC input. A front end unit(AC/DC unit) is required when the SNDBS series is operated with AC input.

(4) Reverse input voltage protection

- Avoid the reverse polarity input voltage. It will break the power supply. It is possible to protect the unit from the reverse input voltage by installing an external diode.

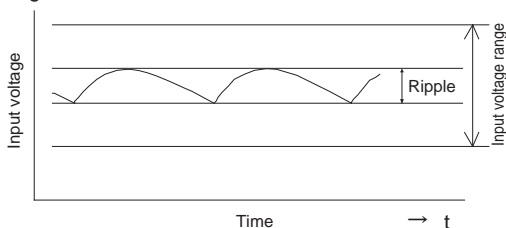

Fig.3.1 Ripple of input voltage

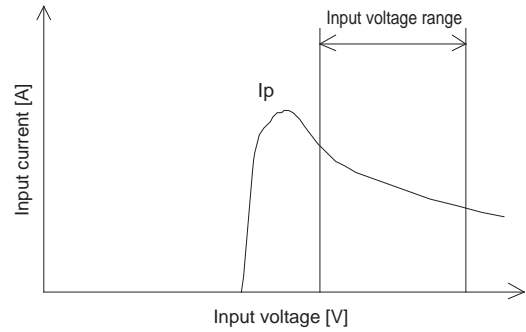

Fig.3.2 Input current characteristics

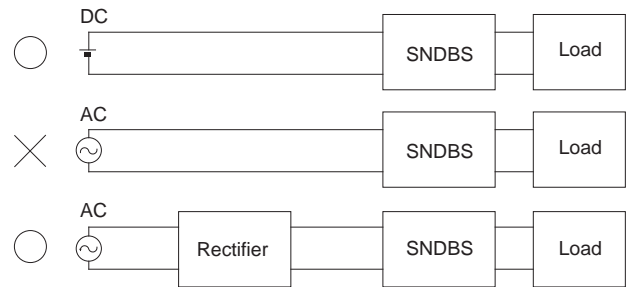

Fig.3.3 Use wit AC input

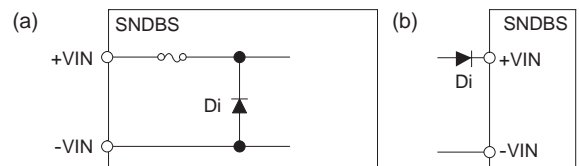

Fig.3.4 Reverse input voltage protection

3.2 Wiring output terminal

- The specified ripple and ripple noise are measured by the method introduced in Fig.3.5.

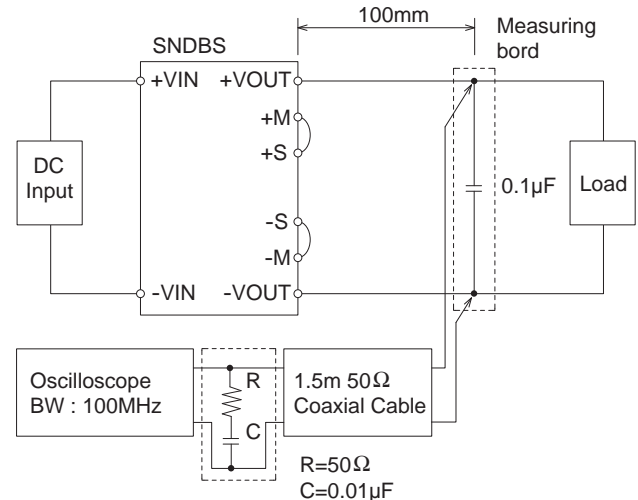

Fig.5.1 Method of Measuring Output Ripple and Ripple Noise

4 Function

4.1 Overcurrent protection

- Overcurrent protection is built-in and comes into effect at over 105% of the rated current. Overcurrent protection prevents the unit from short circuit and overcurrent condition. The unit automatically recovers when the fault condition is cleared.
- When the output voltage drops at overcurrent, the average output current is reduced by intermittent operation of power supply

4.2 Overvoltage protection

- The overvoltage protection circuit is built-in. The DC input should be shut down if overvoltage protection is in operation. The minimum interval of DC recycling for recovery is for 2 to 3 minutes(*).
*The recovery time varies depending on input voltage and input capacity.

Remarks:

Please note that devices inside the power supply might fail when voltage more than rated output voltage is applied to output terminal of the power supply. This could happen when the customer tests the overvoltage performance of the unit.

4.3 Thermal detection / Thermal protection

- Thermal detection (TMP) and protection circuit are built-in.
- When overheat is detected, thermal detection signal (TMP) turns "L" from "H". TMP circuit is designed as shown in Fig.4.1, and specification is shown as in Table 4.1.
- When overheating continues after detecting the TMP signal, the output will be shut down by the thermal protection circuit. When this function comes into effect, input voltage should be shut off, and eliminate all possible causes of overheat condition and lower the temperature of the unit to the normal level.

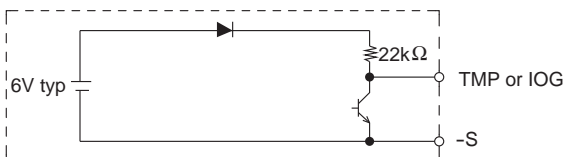

Fig.4.1 TMP, IOG circuit

Table 4.1 Specification of TMP, IOG

No.	Item	TMP	IOG
1	Function	Normal operation "H"	Normal operation "L"
		Overheat detection "L"	Malfunction of inverter "H"
2	Base pin	-S	
3	Level voltage "L"	0.5Vmax at 5mA	
4	Level voltage "H"	5V typ	
5	Maximum sink current	10mA max	
6	Maximum applicable voltage	35V max	

4.4 Inverter operation monitor (IOG)

- By using the inverter operation monitor (IOG), malfunction of the inverter can be monitored. When inverter operation is in following mode or , IOG signal turns "H" from "L" within 1 second. IOG circuit is designed as shown in Fig.4.1 and specification is shown in Table 4.1.

 - Malfunction of inverter.
 - The output voltage drops by 60% or less of the rated voltage.
 - When output wattage is decreased radically to less than 10% of rated wattage.

4.5 Enable signal (ENA)

- When I connect SNDPF or SNDPG to input of SNDBS, you can operate it to start, a stop of SNDPF by connecting ENA. In this case, please set the short-piece of CN8 on 1 pin and 2 pins to prevent the trouble of the power supply.
- When the power supplies are shipped from a factory, they come with a dedicated short-piece being mounted on CN7. If you use SNDPF1000 , you can use the power supplies as they are. If you use SNDPG750 , you must set short-piece to pin2 and 3 on CN7.

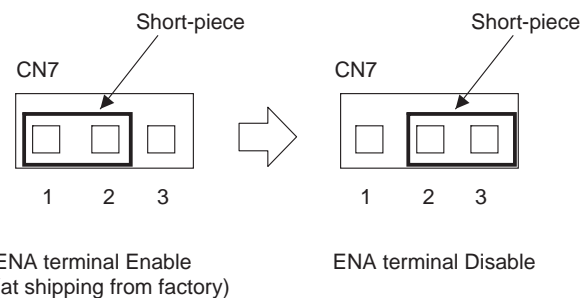

Fig.4.2 Setting of ENA

- If you do not use ENA , remove the short-piece to pin 2 and 3 at CN8 shown in Fig.4.3.

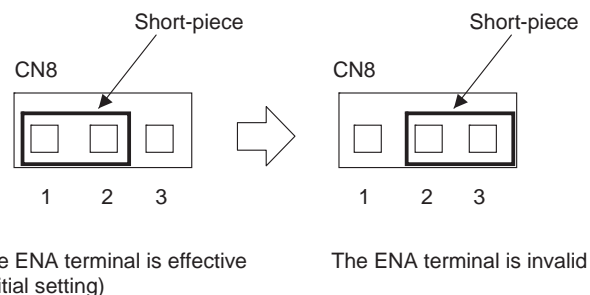

Fig.4.3 Setting of ENA

4.6 Remote ON / OFF (RC2)

■ You can operate the remote ON/OFF function by sending signals to CN4.

Please see Table 4.2 for specifications.

■ Remote ON/OFF circuits (RC2) is not isolated from output.

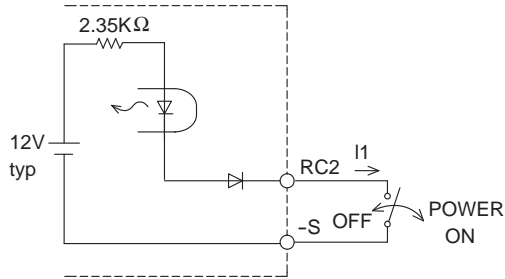

Fig.4.3 Remote ON/OFF (RC2)

Table 4.2 Specification of output side remote ON/OFF (RC2)

No.	Item	RC2
1	Power ON	Open (0.1mA max)
2	Power OFF	Short (3mA min)
3	Base pin	-S

4.7 Remote sensing

(1) When the remote sensing function is not in use

■ If you do not use the remote sensing function, you can short out between +S and +M and between -S and -M on CN3.

When the power supplies are shipped from a factory, they come with a dedicated harness being mounted on CN3.

If you do not use the remote sensing function, you can use the power supplies as they are.

(2) When the remote sensing function is in use

■ Please see Fig.4.2 if you use the remote sensing function.

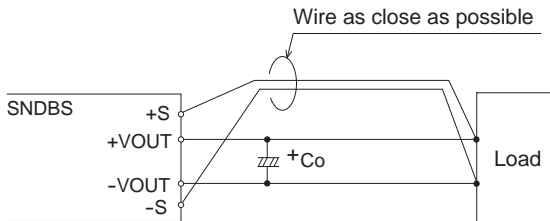

Fig.4.2 Connection when the remote sensing is in use

■ Wire carefully. When a connection of a load line becomes loose (due to such factors as loose screw), the load current flows to the sensing line and internal circuits of the power supply may be damaged.

■ Use a sufficiently thick wire to connect between the power supply and the load and keep the line drop at 0.3V or below.

■ Use a twisted pair wire or a shielded wire as the sensing line.

■ Do not draw the output current from +M, -M, +S or -S.

■ When the remote sensing function is used, the output voltage of the power supply may show an oscillating waveform or the output voltage may dramatically fluctuate because of an impedance of wiring and load conditions.

4.8 Output voltage adjusting

(1) Adjusting method by installed potentiometer

■ Output voltage is adjustable by the internal potentiometer or by applied voltage externally.

The adjustable range is 90 - 110% of the rated output voltage.

To increase an output voltage, turn a built-in potentiometer clockwise.

To decrease the output voltage, turn it counterclockwise

■ The output adjustment range for DBS700B is shown in Fig.4.4.

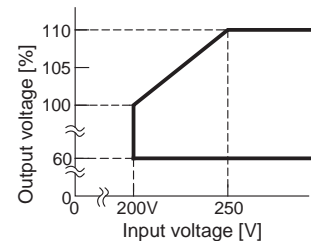

Fig.4.4 SNDBS700B Output Voltage Adjustment Range

(2) Adjusting method by applying external voltage

■ By applying the voltage externally at TRM, output voltage become adjustable.

Output voltage is calculated by the following equation.

$$\text{Output voltage [V]} = \frac{\text{Applied voltage externally [V]}}{1 [\text{V}]} \times \text{Rated output voltage [V]} \quad \textcircled{1}$$

■ If the output voltage decreases to almost 0V, output ripple may become large.

■ When the output voltage adjustment is used, note that the over-voltage protection circuit operates when the output voltage sets too high.

4.9 Isolation

■ For a receiving inspection, such as Hi-Pot test, gradually increase(decrease) the voltage for a start(shut down). Avoid using Hi-Pot tester with the timer because it may generate voltage a few times higher than the applied voltage, at ON/OFF of a timer.

5 Series and Parallel Operation

5.1 Series operation

■ Series operation is available by connecting the outputs of two or more power supplies, as shown below. Output current in series connection should be lower than the lowest rated current in each unit.

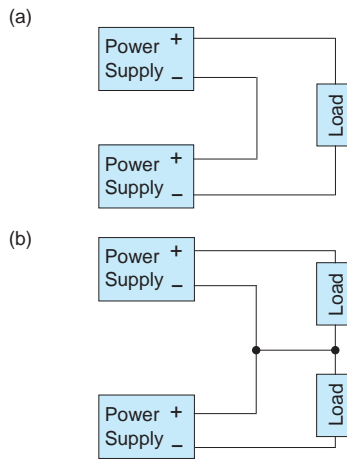

Fig.5.1 Serial operation

5.2 Parallel operation/Master-slave operation

■ Parallel operation is available by connecting the units as shown in Fig.5.2.

■ You can adjust the output voltage in parallel operation by adjusting a potentiometer of just one power supply.

To do so, select one power supply as the master unit and turn the potentiometers of the other (slave) power supplies clockwise to the end.

Once you have done this, you can adjust the output voltage by turning the potentiometer of the master unit.

■ You cannot parallel operate power supplies with different output voltage or electrical power.

■ As variance of output current drew from each power supply is maximum 10%, the total output current must not exceed the value determined by the following equation.

$$\left(\begin{array}{c} \text{Output current in} \\ \text{parallel operation} \end{array} \right) = \left(\begin{array}{c} \text{the rated current} \\ \text{per unit} \end{array} \right) \times (\text{number of unit}) \times 0.9$$

In parallel operation, the maximum operative number of units is 5.

■ When the number of the units in parallel operation increases, input current increases. Adequate wiring design for input circuitry such as circuit pattern, wiring and current for equipment is required.

Connect the sensing line and the power line by one point after connecting each power supply's sensing pins(+S, -S). In multiple operation, sensing wires should be connected between each units for the master connection to a load.

■ Connect the sensing line and the power line by one point after connecting each power supply's sensing pins(+S, -S).

In multiple operation, sensing wires should be connected between each units for the master connection to a load.

■ Output current should be 10% or more of the total of the rated output current in parallel operation. If less than 10%, the IOG signal might become unstable, and output voltage slightly increasing (max5%).

■ IOG signal might be unstable for one second when the units are turned on in parallel operation.

■ Please be connected diode to the +VOUT side to avoid malfunctions and damage.

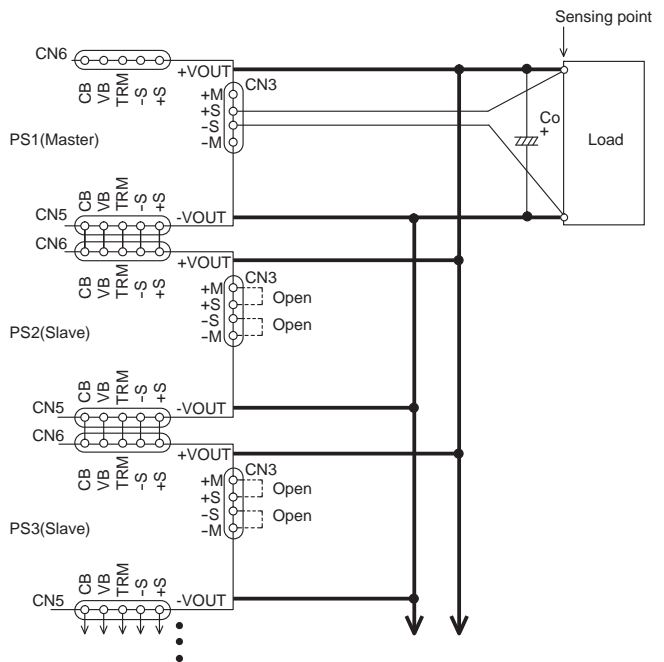

Fig.5.2 Examples of parallel operation

5.3 N+1 Redundancy operation

■ It is possible to set N+1 redundant operation for improving reliability of power supply system.

Purpose of redundant operation is to ensure stable operation in the event of single power supply failure.

Since extra power supply is reserved for the failure condition, so total power of redundant operation is equal to N-1.

■ Please contact us about N+1 redundant operation in details.

6 Implementation · Mounting Method

6.1 Mounting method

- When two or more power supplies are used side by side, position them with proper intervals to allow enough air ventilation. Aluminum base plate temperature around each power supply should not exceed the temperature range shown in derating curve.
- In case of metal chassis, keep the distance between d1 for to insulate between lead of component and metal chassis, use the spacer of 4mm[0.16 inches] or more between d1. If it is less than d1, insert the insulation sheet between power supply and metal chassis.
- Avoid placing the DC input line wires underneath the unit, it will increase the line conducted noise. Make sure to leave an ample distance between the line pattern lay out and the unit. Also avoid placing the DC output line wires underneath the unit because it may increase the output noise. Lay out the pattern away from the unit.

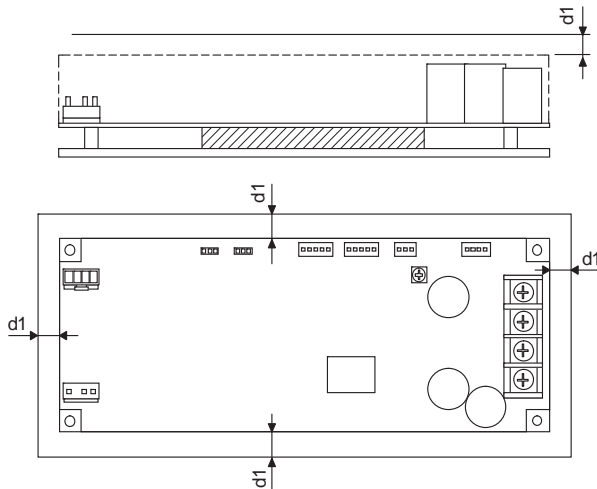

Fig.6.1 Mounting method

6.2 Derating

- Use with the conduction cooling(e.g. heat radiation by conduction from the aluminum base plate to the attached heat sink). Fig.6.2 shows the derating curve based on the aluminum base plate temperature.
- Please measure the temperature on the aluminum base plate edge side (Point A).
- Please consider the ventilation to keep the temperature on the PCB (Point B) less than the temperature of Fig.6.3., Fig.6.5.
- It is necessary to note the thermal fatigue life by power cycle. Please reduce the temperature fluctuation range as much as possible when the up and down of the temperature are frequently generated. Contact us for more information on cooling methods.

■ In the hatched area, the specification of ripple and ripple noise is different from other areas

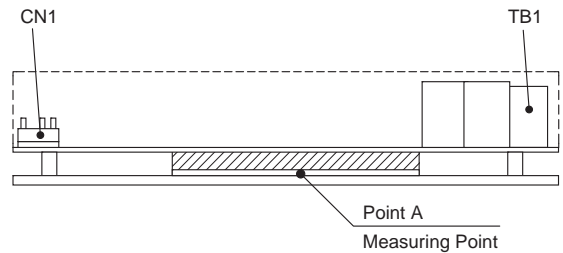
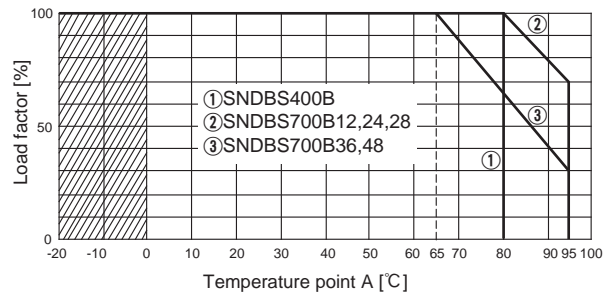

Fig. 6.2 Derating curve (Point A)

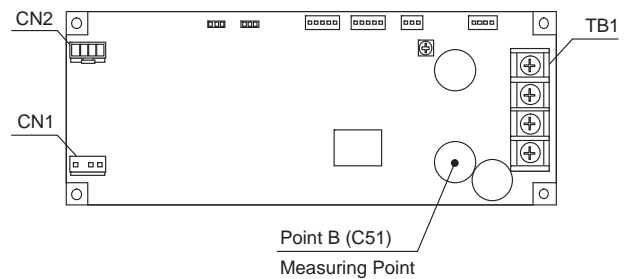
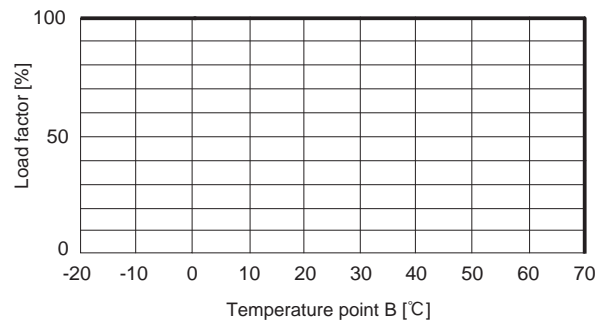

Fig. 6.3 Derating curve (Point A)