

<b>1</b>	<b>Configuration - Model Name Construction</b>	AME-13
<b>2</b>	<b>Series / Parallel operation in Modular power supply</b>	AME-14
	2.1 Series operation .....	AME-14
	2.2 Parallel operation .....	AME-14
<b>3</b>	<b>Functions</b>	AME-14
	3.1 Input voltage range .....	AME-14
	3.2 Inrush current limiting .....	AME-14
	3.3 Overcurrent protection .....	AME-14
	3.4 Peak current protection .....	AME-14
	3.5 Thermal protection .....	AME-15
	3.6 Overvoltage protection .....	AME-15
	3.7 Output ripple and ripple noise .....	AME-15
	3.8 Output voltage adjustment by external .....	AME-15
	3.9 Constant output current adjustment .....	AME-16
	3.10 Remote ON/OFF (RC) .....	AME-16
	3.11 Remote sensing .....	AME-16
	3.12 Variable speed fan .....	AME-17
	3.13 Global inhibit (GI) .....	AME-17
	3.14 Isolation .....	AME-17
	3.15 Alarm .....	AME-18
	3.16 Auxiliary power (AUX) .....	AME-18
	3.17 Medical isolation grade .....	AME-18
<b>4</b>	<b>Peak Current</b>	AME-18
<b>5</b>	<b>Life expectancy and Warranty</b>	AME-19
<b>6</b>	<b>Option</b>	AME-19
	6.1 Option outline .....	AME-19
<b>7</b>	<b>Others</b>	AME-21
	7.1 External output capacitor .....	AME-21

## 1 Configuration - Model Name Construction

The AME series has Order Name which is used for the ordering aside from Model Name.

### Model Name Construction

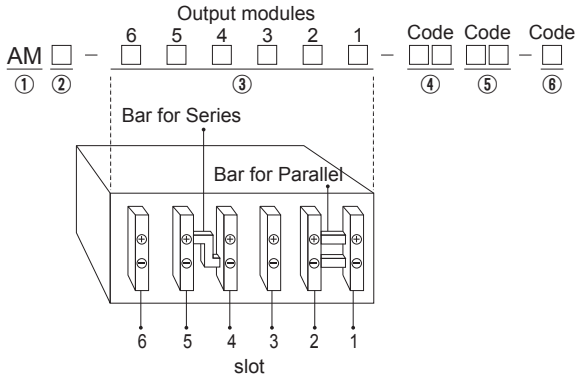

#### ① Model

AM=AME series

#### ② Power

04=400W, 06=600W, 08=800W, 12=1200W

#### ③ Output module configuration

The output module codes are showed in the specifications.

When the slot is blank, "O" (Alphabet) needs to be set.

※The number of slot is different depending on the model.

#### ④ Parallel code

Refer to Table 2.1 Parallel and Series Code.

#### ⑤ Series code

Refer to Table 2.1 Parallel and Series Code.

#### ⑥ Option code

Refer to section 7.

### <Model Name example>

AM12 - 0DCGBA - 0004 - C

- Example of option
- Parallel connection is not necessary.
- Slot1 Module A 5V 12A
- Slot2 Module B 12V 8.5A
- Slot3, 4  
Two Module C in series at 48V 5A
- Slot5 Module D 48V 2.5A
- Slot6 is blank
- AME1200F

### Order Name Construction

① to ③ are same rules as Model Name. After that, add management number (6 digits).

Parallel and series code are not listed on Order name.

<Order Name example>

AM12 - 0DCGBA - □□□□□□

□ : Alphanumeral

□ : management number (6digits)

### Note

- (1) Please select the output module codes from the specifications to correspond with required voltage and current.  
Please select "O" when the slot is blank.
- (2) If the output modules need to be connected in parallel or series, please select Parallel or Series code from Table 1.1.
- (3) At least two slots have to be occupied.
- (4) The following is the list of modules which can be used in series or parallel operation.

	Available output modules
Series setting	A-C, J-L, E4-G4, E-G, S, T
Parallel setting	E4-H4, E-H, S-V, V4, V5

Table 1.1 Parallel and Series Code.

	Code	Slot6	Slot5	Slot4	Slot3	Slot2	Slot1
AME400F/AME600F	00	/	/				
	01					●	●
	02					●	●
	03					●	●
	04			●	●		
	05			●	●	●	●
	06			●	●	●	●
	07			●	●	●	●
AME800F/AME1200F	08		●	●			
	09		●	●		●	●
	0A		●	●		●	●
	0B		●	●		●	●
	0C		●	●	●		
	0D		●	●	●	●	●
	0E		●	●	●	●	●
	0F		●	●	●	●	●
	10	●	●				
	11	●	●			●	●
	12	●	●			●	●
	13	●	●			●	●
	14	●	●	●	●		
	15	●	●	●	●	●	●
	16	●	●	●	●	●	●
	17	●	●	●	●	●	●
18	●	●	●				
19	●	●	●		●	●	
1A	●	●	●		●	●	
1B	●	●	●		●	●	
1C	●	●	●	●			
1D	●	●	●	●	●	●	
1E	●	●	●	●	●	●	
1F	●	●	●	●	●	●	

● : Output terminal  
— : Connection

## 2 Series / Parallel operation in Modular power supply

### 2.1 Series operation (Applying module : A-C, J-L, E4-G4, E-G, S, T)

- Series operation is available with identical output modules.  
The copper bar for series connection is assembled before shipping.
- The output current in series operation is the same as the one of the individual modules that are connected.
- Please note the following items,
  - ① Only identical modules can be connected in series.
  - ② Total of the rated voltage in series has to be 48V or less.  
Total output voltage should be adjusted within 60V.
  - ③ The series operation is not available along with the parallel operation.
  - ④ Constant current function is not available.  
Please contact us for any other conditions.

### 2.2 Parallel operation (Applying module : E4-H4, E-H, S-V, V4, V5)

- Parallel operation is available with identical output modules.  
With parallel operation, the output modules need to be tuned internally, and it cannot be done in the field. The copper bar for parallel operation is assembled before shipping.
- Output current in parallel operation.  
Current ratings for output modules connected in parallel are derated by 10%.  
Ex.: AM06-HHCB-0400
  - Parallel code 04 means slots 3 and 4 are connected in parallel.
  - The output modules for slot 3 and 4 are "H", so the rated output current is shown below.  
Current = (5+5) × 0.9=9A
- Please note the following for parallel operation.
  - ① The remote sensing is not available along with parallel operation.
  - ② The peak capability is invalid in parallel operation.
  - ③ In case that output voltage adjustment is required for modules connected in parallel, the modules should be adjusted individually. If precision adjustment is required, remove the copper bar between modules, adjust the output voltages individually, and refix the copper bar. The output voltage difference will appear as load regulation. To reduce the regulation, adjust the each output voltage to be the same value as possible.
  - ④ When the output current changes rapidly such as pulse load, the output voltage fluctuation (dynamic load regulation) may increase. Therefore, please consult us the unit will be used for such an application.
  - ⑤ Specification value of ripple and ripple noise is tripled.
  - ⑥ Constant current function is not available.
- When in series and parallel, the output voltage at the start-up might have the step as shown in Fig.2.1.

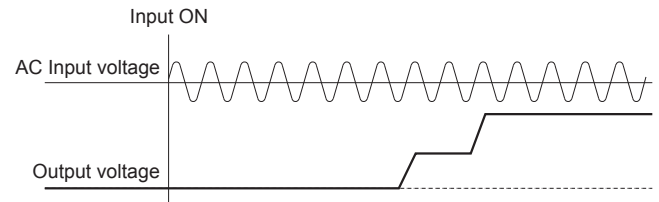

Fig.2.1 Start-up waveform in series and parallel operation

## 3 Functions

### 3.1 Input voltage range

- The input voltage range is from 85 VAC to 264 VAC.  
The rated input voltage range for the safety approvals is from 100VAC to 240VAC (50/60Hz).
- If the input voltage was out of the above range, the power supply might not meet the specification or might fail.  
Please do not apply the square wave of the UPS, the inverter and so on to the power supply.
- When DC input is required, please contact us.

### 3.2 Inrush current limiting

- If the switch is installed on the input, please select the one which can work at the inrush current.
- The relay is used in the inrush current limiting circuit. If the interval of the input on/off was short, the inrush current limiting might not work correctly. So, please make its interval long enough.  
And, it makes the primary and the secondary inrush current.

### 3.3 Overcurrent protection

- The unit has the overcurrent protection which will activate at 105% of the rated current, 101% of the peak current or more. The output will automatically recover when the overcurrent condition is resolved.  
Please do not use the unit with short circuit and/or under the overcurrent condition.
- Hiccup mode  
When the overcurrent protection activates and the output voltage drops, the output will get intermittent to reduce the average current.  
The over current protection of the module R is not hiccup mode.

### 3.4 Peak current protection (Applying module : G4, G, H4, H, U)

- The unit has the peak current protection. (Refer to the item 4 for the detail.)  
When the peak current protection activates, the output stops.  
After a few seconds, the output will recover automatically. However, it will stop again if the overcurrent condition was not resolved.  
\*The recovery time depends on the input voltage and the load condition.

### 3.5 Thermal protection

- The unit has the thermal protection.
  - The thermal protection might activate and shut down the output under the following conditions.
    - ①The case that the output current and/or the ambient temperature exceed the derating curve.
    - ②The case that the fan stops working or the air volume is decreased by blocking the fan.
- When the thermal protection activates, outputs on all output modules will shut down.
- However, the module R can shut down individually.
- When either one of the following actions is taken, the output will recover.
- ①Turn the input voltage off and solve all of overheating cause. Then, turn the input on after enough time to cool the unit down.
  - ②Turn all outputs off by GI terminal and solve all of overheating cause. Then, turn all outputs on by GI terminal after enough time to cool the unit down.

### 3.6 Overvoltage protection

- When the overvoltage protection activates, outputs on all output modules will shut down.
- When either one of the following actions is taken, the output will recover.
- ①Turn the input voltage off and solve all of overvoltage cause. Then, turn the input on after ten seconds.
  - ②Turn all outputs off by GI terminal and solve all of overvoltage cause. Then, turn all outputs on by GI terminal after ten seconds.
- \*The recovery time depends on such factors as input voltage.
- Module E4 to H4, E to H, S to V, V4 and V5 have the overvoltage protection to follow up to the output voltage in addition to a standard overvoltage protection. It will activate when the output voltage exceeds the setting voltage.
- If the external voltage was applied to the output of the power supply, the internal components might be damaged.

### 3.7 Output ripple and ripple noise

- The measurement environment would affect the ripple noise.
- Fig.3.1 is the recommended measurement method.

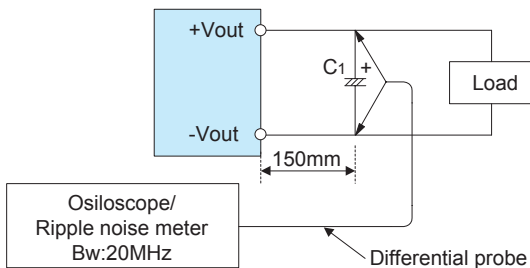

C1 : Aluminum electrolytic capacitor 22μF

Fig.3.1 Measuring method of Ripple and Ripple Noise

Remarks :

The output ripple and noise might not be measured correctly by the flux of magnetic force from the power supply which crosses the ground wire of the probe.

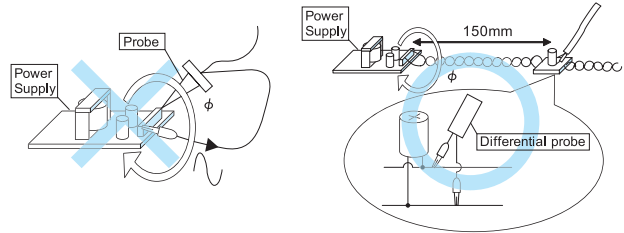

Bad example

Good example

Fig.3.2 Example of measuring output ripple and noise

### 3.8 Output voltage adjustment by external

- To increase an output voltage, turn a built-in potentiometer clockwise. To decrease the output voltage, turn it counterclockwise.
  - The output voltage of module E4 to H4, E to H, S to V, V4 and V5 can be adjusted by external. When the VTRM\_EN and COM terminals on CN3 are shorted and the power supply starts up, the VTRM will be enabled. The output voltage can be adjustable from approximately 0V to the upper limit of the output adjustment range by external voltage applied between VTRM and COM on CN3. In this case, the output voltage will be based on the calculation ①. However, even if 3.0V or more (3.5V or more for output module V) is applied, the value cannot be set to exceed the upper limit of the output voltage adjustment range.
- Do not set the external voltage of the terminal to -0.3V or less, and 5.0V or more.

$$\text{Output voltage [V]} = \frac{\text{The voltage between VTRM and COM [V]}}{2.5 \text{ [V]}} \times \text{Rated output voltage [V]} \cdots \text{①}$$

\*When using a module, use the corresponding rated output voltage (Ex.E4 should use E, H4 should use H, etc.)

- When the VTRM is enabled, the potentiometer for the output voltage adjustment will be disabled.
- The conversion of VTRM Enable and Disable requires removing and reinstating AC power.
- When the output voltage is adjusted by the external, the output voltage will drop to approximately 0V if the VTRM terminal got disconnected.
- When the output voltage is adjusted to less than the adjustment voltage range, the ripple or the ripple noise may be bigger than the specs.

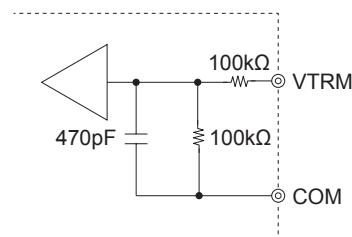

Fig.3.3 VTRM Internal circuit

### 3.9 Constant output current adjustment (Applying module : E4-H4, E-H, S-V, V4, V5)

■The constant output current can be adjustable by the external voltage applied to between ITRM and COM on CN3. When the ITRM terminal voltage is set at less than 2.5V, the output current will be based on the calculation ②.

Do not set the external voltage of the terminal to -0.3V or less, and 5.0V or more.

When the output current is adjusted to around 0A, the unit might be unstable.

The external resistor or voltage is required for the constant output current adjustment.

$$\text{Output current [A]} = \frac{\text{The voltage between ITRM and COM [V]}}{2.5 \text{ [V]}} \times \text{Rated output current [A]} \cdots \text{②}$$

\*When using output module V5, use the rated output current of output module V.

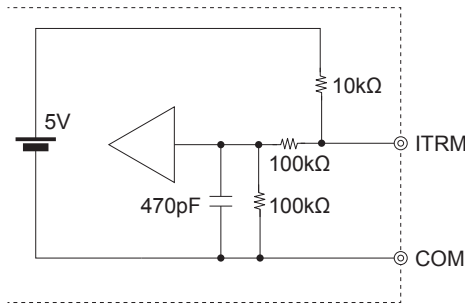

Fig.3.4 ITRM Internal circuit

**Note :**

- If the output voltage becomes less than 5% of the rated voltage during constant current operation, the output may be unstable. Please evaluate the unit under actual conditions carefully before using the constant current function.
- When the output impedance is low like the high capacitive load, the output may be unstable. Please contact us for the detail.

### 3.10 Remote ON/OFF(RC)

■Each output module have remote ON/OFF functions. The output voltage can be turned on/off by the signal to RC terminal in CN3 on each modules.

■The remote ON/OFF circuit (RC, RCG) is isolated from the input, outputs, FG and other function terminals.

■Auxiliary power (AUX) for remote ON/OFF.

The power supply has the auxiliary power (AUX) for the remote ON/OFF.

The auxiliary power (AUX) is isolated from the input, outputs, and FG.

Fig. 3.5 is the example of the remote ON/OFF with AUX.

■Please note the followings for the remote ON/OFF function.

- ①The output stops when 4.5V to 12.5V of the voltage is applied to RC.

- ②The built-in fan does not stop even if the output is turned OFF by the remote ON/OFF.
- ③When the output is turned off by the remote on/off, the LV alarm will be delivered.
- ④This function individually operates on each output module.

■The Remote ON/OFF circuit on each output module can operate individually.

The detail of the "Global inhibit function" to turn all output modules off at the same time is shown in the item 3.13.

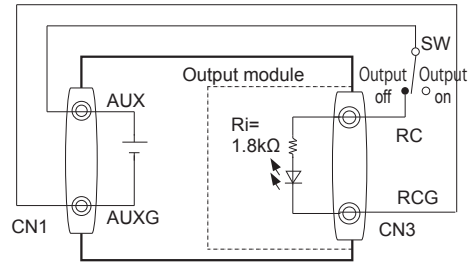

Fig.3.5 Example of remote ON/OFF

Table 3.1 Remote ON/OFF specification

Connection method		Fig.3.5 Remote SW
SW Logic	Output on	SW open (0-0.5V between RC and RCG)
	Output off	SW short (4.5-12V between RC and RCG)
Bases pin		CN3 RCG

### 3.11 Remote sensing (Applying module : E4-H4, E-H, S-V, V4, V5)

■These models have the remote sensing function.

When the remote sensing is not used. +S and -S can be left open.

■Please see Fig.3.6 if you use the remote sensing function.

■When you use the remote sensing function, please wire from +S and -S on CN3. Harnesses are available for purchase.

For details, refer to the item of option parts.

■Please consider the following when using remote sensing.

- ①Be sure connections are made properly. If the load wire is not connected correctly, a load current may flow through the sensing wire, which could damage circuitry inside the power supply.
- ②Wire of an appropriate type and gauge should be used to connect the power supply to the load. Line drop should be less than 0.3V.
- ③Use a twisted pair wire or a shielded wire as the sensing line.
- ④Do not draw the output current from +S or -S.
- ⑤The impedance of the wiring and the load might cause problems such as the unstable output voltage and bigger output voltage fluctuation.  
When the output voltage is unstable, C1, R1, R2 in Fig. 3.6 will be effective.
- ⑥When power supplies are connected in parallel, the remote sensing function is not available.

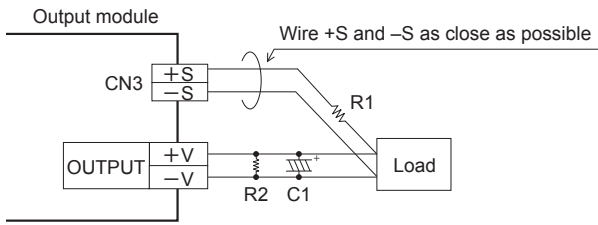

Fig. 3.6 Use example of remote sensing

### 3.12 Variable speed fan

- The power supply has built-in variable speed cooling fan. The fan speed changes by load and ambient temperature.

### 3.13 Global inhibit (GI)

- The unit has the Global inhibit function. Global inhibit is the control signal input which turns all outputs off by supplying the current into GI2. Table 3.2 is specifications and Fig.3.7 is use examples for Global inhibit.
- The Global inhibit circuit (GI2, GIG) is isolated from the input, outputs, FG, AUX and other function terminals.
- Please note the following when using the Global inhibit function.
  - ① The output can be turned off by supplying the current into GI2 pin.
  - ② The current into GI2 pin is 3mA typ (12mA max).
  - ③ The PR signal will get "High" when all output modules are turned off by the Global inhibit function.
  - ④ When stopping outputs by Global inhibit, the built-in fans also stop.
  - ⑤ AUX is available even when outputs stop by Global inhibit.
  - ⑥ When stopping outputs by Global inhibit, the derating is required for AUX. Please refer to the item 3.16.
  - ⑦ If the voltage or the current which exceeds the value in table 3.2 were supplied into GI2 pin, the output might not be generated correctly.
  - ⑧ Start time is 1,000ms max.

Table 3.2 Global inhibit specification

Connection method		Fig. 3.7 (a)	Fig. 3.7 (b)	Fig. 3.7 (c)
SW Logic	Output on	SW open (0.1mA max)	SW open (0.1mA max)	SW short (0.5V max)
	Output off	SW short (1.5mA min)	SW short (1.5mA min)	SW open (0.1mA max)
Bases pin		GIG	AUXG	GIG,AUXG

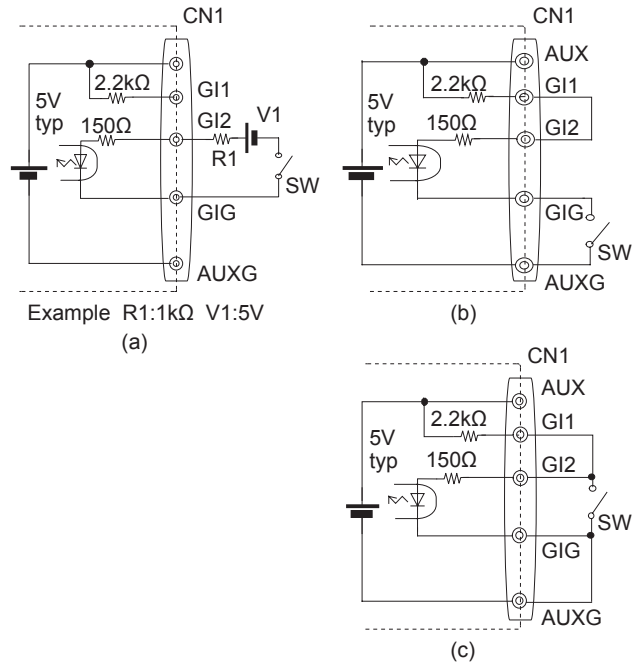

Fig.3.7 Connection examples for Global inhibit

### 3.14 Isolation

- When the Hi-Pot test for the receiving inspection, etc is conducted, the voltage should be increased gradually. Also, when shutting the voltage off, it should be decreased gradually by using the dial. Please do not use the Hi-pot tester which has the timer because it might generate unwanted high voltage when timer is on.
- When the isolation test between "the input and outputs", "the input and FG" and "outputs and FG (Except output module V, V4, V5)" is conducted, all outputs and terminals for all functions should be shorted.
- When the isolation test between "outputs and FG (output modules V, V4, V5)" is conducted, output and the function terminal of CN3 should be shorted.
- \* If the other function terminals are not opened, the internal components might be damaged.

### 3.15 Alarm

■The unit has two types of alarm below. Table 3.3 is the detail of the alarm.

- ①PR: abnormal input voltage, fan alarm
- ②LV: drop and shut-off of output voltage

Table 3.3 Explanation of alarms

	Alarm	Output of alarm
PR	When the input voltage is abnormal (low input voltage) or the fan stops, the alarm signal is generated from CN1.	Open collector method Good:Low (0.5Vmax at 5mA) Fail:High (50Vmax)
LV	When the rated output voltage decreases or stops, the alarm signal is generated from CN3.  Note: When the overcurrent protection activates, the alarm will be unstable.	Open collector method Good:Low (0.5Vmax at 5mA) Fail:High (50Vmax)

The alarm circuits (PR and LV) are isolated from others (the input, outputs, FG, AUX and other function terminals).

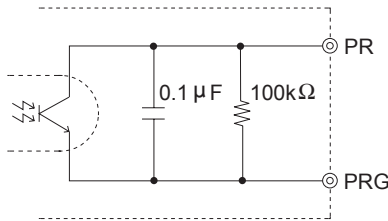

Fig.3.8 PR internal circuit

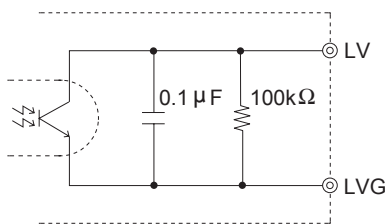

Fig.3.9 LV internal circuit

■Please note the followings when you use the alarm (LV signal).

- ①If the output voltage is turned off by the remote ON/OFF circuit, the LV signal will get "High".
- ②If the output voltage drops below the lower limited of adjustment range, the LV signal may get "High".

### 3.16 Auxiliary power (AUX)

■The unit has the auxiliary power (AUX: 5V1A) in CN1 to provide for the remote ON/OFF and external circuits.

■When the Global inhibit function activates, the following derating for the AUX is required.

Derating for AUX:  $I_o(AUX) \leq 0.5A$

■The AUX circuit(AUX, AUXG) is isolated from the input, outputs, the FG, and other function terminals except G11.

■If the output current of the AUX exceed 1A, the unit might be damaged or malfunction.

When the DC-DC converter is connected to the AUX, the current might be severalfold of the normal current when starting up. Please check the current.

■The maximum external capacitor to the AUX is 47μF.

### 3.17 Medical Isolation grade

■AME series meets 2MOOPP

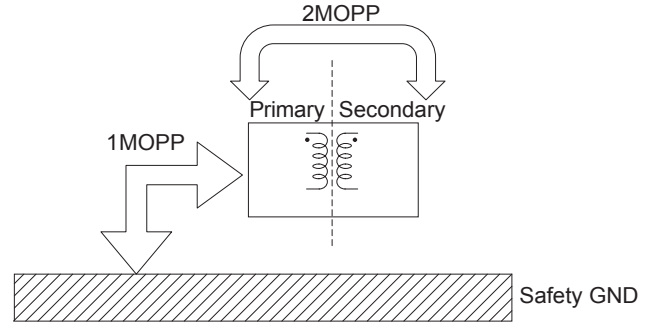

Fig.3.10 Medical Isolation Grade

## 4 Peak Current

(Applying module : G4, G, H4, H, U)

■Some output modules have the peak capability of the following conditions.

- $t1 \leq 5sec$
- $I_p \leq \text{Rated peak current}$
- $I_{ave} \leq \text{Rated current}$
- $Duty = \frac{t1}{t1+t2} \times 100 [\%] \leq 35\%$

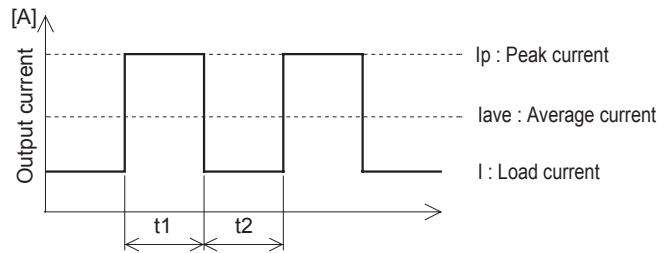

Fig.4.1 Peak current

■Derating curve for input voltage

The derating curves with respect to input voltage are shown in "Derating".

## 5 Life expectancy and Warranty

■ Life expectancy

Life expectancy is as follows.

Table 5.1 Life expectancy (AME400F)

Mounting method	Input Voltage	Average ambient temperature (yearly)	Life expectancy	
			0% ≤ lo ≤ 75%	75% < lo ≤ 100%
All mounting direction	85 to 264VAC	Ta = 40°C or less	10 years	7 years
		Ta = 50°C	10 years	4 years

Table 5.2 Life expectancy (AME600F)

Mounting method	Input Voltage	Average ambient temperature (yearly)	Life expectancy	
			0% ≤ lo ≤ 75%	75% < lo ≤ 100%
All mounting direction	85 to 170VAC	Ta = 40°C or less	10 years	4 years
		Ta = 50°C	7 years	2 years
	170 to 264VAC	Ta = 40°C or less	10 years	4 years
		Ta = 50°C	7 years	2 years

Table 5.3 Life expectancy (AME800F)

Mounting method	Input Voltage	Average ambient temperature (yearly)	Life expectancy	
			0% ≤ lo ≤ 75%	75% < lo ≤ 100%
All mounting direction	85 to 264VAC	Ta = 40°C or less	10 years	9 years
		Ta = 50°C	10 years	4 years

Table 5.4 Life expectancy (AME1200F)

Mounting method	Input Voltage	Average ambient temperature (yearly)	Life expectancy	
			0% ≤ lo ≤ 75%	75% < lo ≤ 100%
All mounting direction	85 to 170VAC	Ta = 30°C or less	10 years	9 years
		Ta = 40°C	10 years	4 years
	170 to 264VAC	Ta = 40°C or less	10 years	4 years
		Ta = 50°C	7 years	2 years

■ Life expectancy (R(t)=90%) of fan depends on use conditions as shown in Fig.5.1.

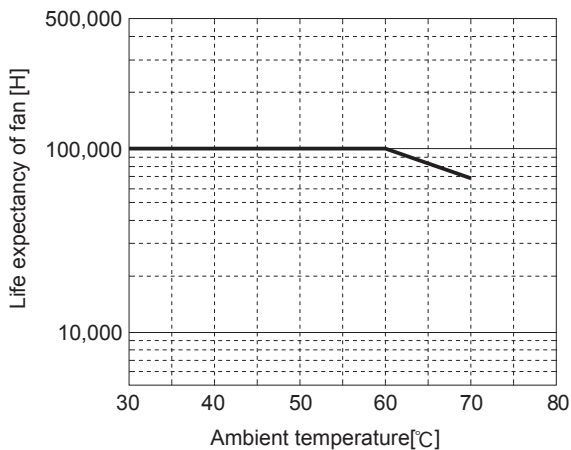

Fig.5.1 Life expectancy of fan

■ Warranty term

Warranty term depends on the conditions in Table 5.5, 5.6, 5.7 and 5.8 and its maximum is 5 years.

If the unit was used under the out of the derating curve, it will be out of warranty.

Table 5.5 Warranty term (AME400F)

Mounting method	Input Voltage	Average ambient temperature (yearly)	Warranty term	
			0% ≤ lo ≤ 75%	75% < lo ≤ 100%
All mounting direction	85 to 264VAC	Ta = 40°C or less	5 years	5 years
		Ta = 50°C	5 years	3 years

Table 5.6 Warranty term (AME600F)

Mounting method	Input Voltage	Average ambient temperature (yearly)	Warranty term	
			0% ≤ lo ≤ 75%	75% < lo ≤ 100%
All mounting direction	85 to 170VAC	Ta = 40°C or less	5 years	4 years
		Ta = 50°C	5 years	2 years
	170 to 264VAC	Ta = 40°C or less	5 years	4 years
		Ta = 50°C	5 years	2 years

Table 5.7 Warranty term (AME800F)

Mounting method	Input Voltage	Average ambient temperature (yearly)	Warranty term	
			0% ≤ lo ≤ 75%	75% < lo ≤ 100%
All mounting direction	85 to 264VAC	Ta = 40°C or less	5 years	5 years
		Ta = 50°C	5 years	3 years

Table 5.8 Warranty term (AME1200F)

Mounting method	Input Voltage	Average ambient temperature (yearly)	Warranty term	
			0% ≤ lo ≤ 75%	75% < lo ≤ 100%
All mounting direction	85 to 170VAC	Ta = 30°C or less	5 years	5 years
		Ta = 40°C	5 years	4 years
	170 to 264VAC	Ta = 40°C or less	5 years	4 years
		Ta = 50°C	5 years	2 years

## 6 Option

### 6.1 Option outline

■ Please contact us in advance as regards detailed specifications and delivery.

■ Please refer to "1. Configuration - Model Name Construction" for ordering methods.

● -A

- Auxiliary power (AUX) is 12V0.1A instead of 5V1A.

● -R

- The logic of the remote ON/OFF is reversed.
- Even if the input voltage is applied to the unit which has -R option, the output will not be generated unless the voltage is applied to the RC terminal.

Turn on : 4.5 to 12.5[V] between RC and RCG.  
 Turn off : 0-0.5[V] between RC and RCG.



- All output modules have the reversed logic of the remote ON, if the -R is specified.
- The harness for CN3 is required when using this option.
- Please contact us if the mix of the standard and the reversed logic is required.

## ●-J2

- Every module in the unit of -J2 option have Molex connectors instead of a terminal block.
- Please contact us for details about appearance.
- The maximum current per pin is 8A.

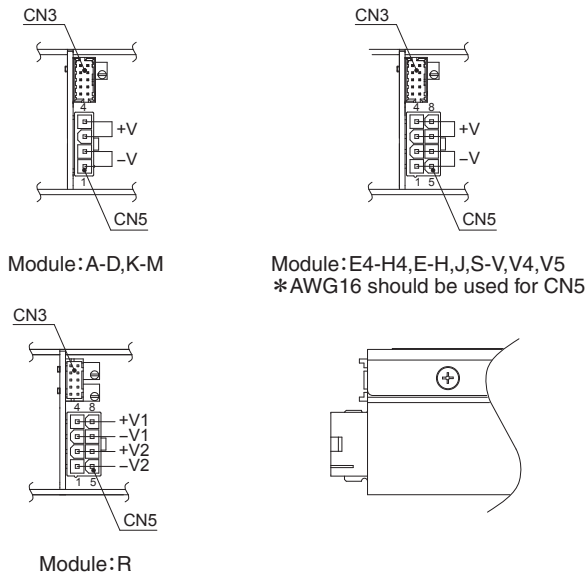

Fig.6.1 Example of -J2 option

Table 6.1 Connectors and Terminals for -J2 option  
(Applying module : A-D, K-M)

Connector	Mating Connector	Terminal	Mfr.
CN5	39303046	39014041	45750-3111 Molex

Table 6.2 Connectors and Terminals for -J2 option  
(Applying module : E4-H4, E-H, J, S-V, V4, V5, R)

Connector	Mating Connector	Terminal	Mfr.
CN5	39300080	39012085	45750-3111 Molex

Table 6.3 Function of specification pins

Pin numbers	Applying module		
	A-D, K-M	E4-H4, E-H, J, S-V, V4, V5	R
1	-V	-V	-V2
2	-V	-V	+V2
3	+V	+V	-V1
4	+V	+V	+V1
5	-	-V	-V2
6	-	-V	+V2
7	-	+V	-V1
8	-	+V	+V1

## ●-J3

- The unit of -J3 option has the following connectors for functions.

Table 6.4 Connectors and Terminals for -J3 option

	Connector	Mating Connector	Terminal	Mfr.
CN1	87833-1031	51110-1056	50394-8051	Molex
CN3				
CN2	87833-0831	51110-0856	50394-8051	Molex

## ●-C

- Except a certain (e.g.terminal, potentionmeter), PCB is coated.

## ●-F3

- The cooling fan direction is reversed from the standard model.
- Fig. 6.2 is the direction of air flow and Fig. 6.3 is the temperature derating.
- Please contact us for the life expectancy of fan.



Fig. 6.2 Air flow(-F3 option)

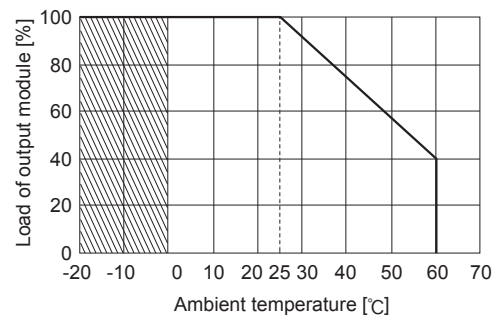

Fig.6.3 Derating curve for ambient temperature (-F3 option)

## ●-G

- The spec of leakage current is lower than the standard model.
- Differences from standard model are summarized in Table 6.5.

Table 6.5 Low leakage current type

Leakage Current (240VAC)	0.15mA max
Conducted Noise	N/A
Output Ripple Noise	150% of standard units

## ●-I3

- The power supply provides an "Extended-UART" digital interface.
  - Extended-UART is the communication protocol that enable single-wire and bidirectional communications among multiple machines by using the software with being isolated from UART which is the general purpose communication.
- Please refer to "AME Series Extended-UART Manual" for details.

Table 6.6 Pin configuration and function of CN1

Pin No.	Function	Ground level
1	AUX : Auxiliary power	AUXG
2	AUXG : Auxiliary power ground	AUXG
3	GI1 : Global inhibit	AUXG
4	AUXG : Auxiliary power ground	AUXG
5	GI2 : Global inhibit	GIG
6	GIG : Global inhibit ground	GIG
7	INFO : Extended UART signal	INFOG
8	INFOG : Extended UART signal ground	INFOG
9	PR : PR Alarm	PRG
10	PRG : PR Alarm ground	PRG

Table 6.7 Pin configuration and function of CN2

Pin No.	Function	Ground level
1	N.C. : No connection	-
2	SGND : Signal ground	SGND*
3	N.C. : No connection	-
4	N.C. : No connection	-
5	ADDR0 : Address bit 0	SGND*
6	ADDR1 : Address bit 1	SGND*
7	ADDR2 : Address bit 2	SGND*
8	SGND : Signal ground	SGND*

Do not connect anything to an N.C. pins.

\*SGND is not isolated from AUXG.

Table 6.8 Matching connectors and terminals

Connector	Housing	Terminal	Mfr.
CN1	S10B-PHDSS	PHDR-10VS	Reel : SPHD-002T-P0.5 Loose : BPHD-001T-P0.5 *1 BPHD-002T-P0.5 *1 J.S.T
CN2	S8B-PHDSS	PHDR-8VS	

\*1 The manufacturer can offer only ratchet hand tool.

■INFO and INFOG terminals are isolated from input, output, FG, AUX and other function terminals.

■ADDR0, ADDR1, ADDR2 and SGND terminals are isolated from input, output, FG and CN3.

## ●-|

- The power supply provides a PMBus digital interface
- Please refer to “AME Series PMBus Manual” for details

Table 6.9 Pin configuration and function of CN2

Pin No.	Function	Ground level
1	SDA : Serial data	SGND*
2	SGND : Signal ground	SGND*
3	SCL : Serial clock	SGND*
4	SMBA : SMBAlert	SGND*
5	ADDR0 : Address bit 0	SGND*
6	ADDR1 : Address bit 1	SGND*
7	ADDR2 : Address bit 2	SGND*
8	SGND : Signal ground	SGND*

\*SGND is not isolated from AUXG

Table 6.10 Matching connectors and terminals

Connector	Housing	Terminal	Mfr.
CN2	S8B-PHDSS	PHDR-8VS	Reel : SPHD-002T-P0.5 Loose : BPHD-001T-P0.5 *1 BPHD-002T-P0.5 *1 J.S.T

\*1 The manufacturer can offer only ratchet hand tool.

- CN2 is isolated from input, output, FG and CN3

## 7 Others

### 7.1 External output capacitor

- If the external capacitor is too large, the power supply might not start up.

Table 7.1 Connectable external output capacitance

Module code	Capacitance [μF]
J	0 to 47,000
A	0 to 47,000
K	0 to 18,000
B	0 to 18,000
L	0 to 18,000
C	0 to 12,000
M	0 to 6,800
D	0 to 2,200
E4	0 to 47,000
E	0 to 47,000
S	0 to 18,000
F4	0 to 18,000
F	0 to 18,000
T	0 to 18,000
G4	0 to 12,000
G	0 to 12,000
U	0 to 3,300
H4	0 to 2,200
H	0 to 2,200
V4	0 to 470
V	0 to 470
V5	0 to 470
R	0 to 1,000