



Qualification of DHS50A,100A,200A to Railway applications

(General Standard EN50155)
(Shock and Vibration Standard EN61373)



Contents

	Page
1. Purpose	A-1
2. Scope	A-1
3. Qualification to EN 50155	A-1
3.1 Visual inspection	A-1
3.2 Performance test	A-1
3.3 Cooling test	A-2
3.4 Dry heat test	A-2
3.5 Damp heat test, cyclic	A-2
3.6 Supply overvoltages	A-2
3.7 Surges, electrostatic discharge and transient burst susceptibility	A-2
3.8 Radio interference test	A-3
3.9 Insulation test	A-3
3.10 Salt mist test	A-3
3.11 Vibration, shock and bump test	A-3
3.12 Water tightness test	A-3
4. Qualification to EN 61373	A-3
4.1 Vibration test	A-3
4.2 Shock test	A-4
5. External circuit for Surge Protection	A-5
6. Life cycle by Heat cycle	A-6

1. Purpose

To verify compliance of our product to shock and vibration standard EN61373, parts of general standard EN50155 for electronic equipment used in Railway applications by existing test data and additional test.

2. Scope

The following products which have the input voltage range suited to railway market are as follows.

- DHS50A05 ▪ DHS50A12 ▪ DHS50A15 ▪ DHS50A24
- DHS100A05 ▪ DHS100A12 ▪ DHS100A15 ▪ DHS100A24
- DHS200A05 ▪ DHS200A12 ▪ DHS200A15 ▪ DHS200A24

3. Qualification to EN 50155

3.1 Visual inspection

No marked damage appears during or after the following test mentioned on this document.

3.2 Performance test

Refer to Performance data for each product on web site.

Address: [Cosel HP](#) ▶ [Technical Data](#) ▶ [Technical data down load](#)
 ▶ [DHS series](#) ▶ [Performance data](#) for each product

To continue operation under 10ms interruptions, input electrical capacitor is required. Example for calculation is shown below.

In case of DHS100A05 75% load,

Pin : Input Power from "Input power(by Load Current) test data" on performance data

V1 : Rated input voltage

V2 : 60V(Minimum operating Input voltage)

T : Interruption time

$$C_{in} = \frac{2 \times P_{in} \times T}{V_1^2 - V_2^2} = \frac{2 \times 90 \times 0.01}{(110^2 - 60^2)} = 210 \text{ [uF] or more}$$

For Railway Applications

3.3 Cooling test

Refer to Performance data for each product.

Test data at -35 °C is shown on Ambient Temperature Drift and Minimum Input for Regulated Output Voltage test data.

3.4 Dry heat test

Refer to High temp./overload test of Safety test results on appendix 1.

No failure with overload at 85 °C on base plate during 48 hours is confirmed.

The base plate and ambient temperature are different. Therefore the design, in which the base plate temperature is within specification even if ambient temperature goes up, is required.

3.5 Damp heat test, cyclic

Refer to High temp./High humidity bias test of Reliability Test results on appendix 2.

No degradation of electric characteristics after 1000h at 85 °C and 85%Rh is confirmed.

3.6 Supply overvoltages

Refer to High temp./overload test of Safety test results on appendix 1.

No smoke, and no fire at 220Vdc input is confirmed.

Input voltage 154V (rated voltage 110Vdc x 1.4) is within specification.

3.7 Surges, electrostatic discharge and transient burst susceptibility

Refer to EMI/EMS test results on appendix 3.

3.7.1 Surges

By Surge immunity test (EN61000-4-5), no stop, no drop down, no abnormality, and no degradation under condition of Line to Line 2kV, Line to earth 4kV is confirmed.

3.7.2 Electrostatic discharge susceptibility test

By Static electricity immunity test (EN61000-4-2), no function failure under condition of contact discharge 8kV is confirmed.

For Railway Applications

3.7.3 Transient burst susceptibility test

By Electrical fast transient/burst immunity test(EN61000-4-4), no function failure under condition of 4 kV peak voltage is confirmed.

3.8 Radio interference test

By Radiated, radio-frequency, electromagnetic field immunity test on EMI/EMS test results, no function failure under condition of 10V/m field strength is confirmed.

By Immunity to conducted disturbances, induced by radio - frequency fields test, no function failure under voltage level 10V is confirmed.

Concerning other condition, contact us. The each condition is dealt with.

3.9 Insulation test

By Withstand voltage test on Safety test results, no insulation breakdown, no flashover under condition of 4200Vac and 700Vdc is confirmed.

3.10 Salt mist test

Water proof design is required in order to prevent water infiltration.

Especially be careful when the PCB board under the product, because it is weak.

3.11 Vibration, shock and bump test

Refer to 4. Qualification to EN 61373.

3.12 Water tightness test

Basically not required as equipment inside rolling stock. Water proof design may be required depending on equipment.

4. Qualification to EN 61373

4.1 Shock test

By Impact test on Reliability test results, no degradation of electric characteristics, no crack at solder joint and no marked damage of appearance under condition of 20G(196.1m/s²) one time each X, Y and Z axis is confirmed.

4.2 Vibration test

4.2.1 Test conditions

Vibration condition: 5G(49m/s²) 5-150Hz X, Y, Z axis 5hour/axis
 Input Voltage: 140V
 Output: No load
 Model:

- DHS50A series
- DHS100A series
- DHS200A series

 In each series,one for each output voltage

External component: Input rectifier circuit only against 100Vac input

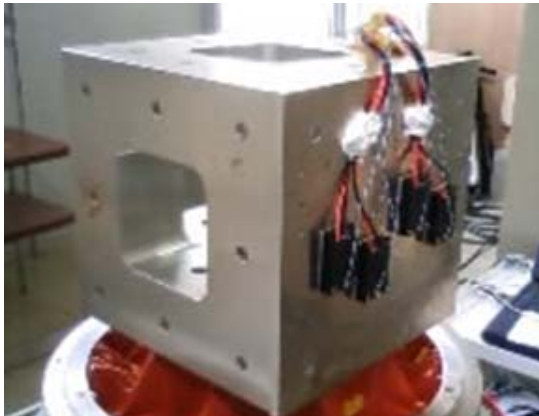

Fig.4.2.1 X axis

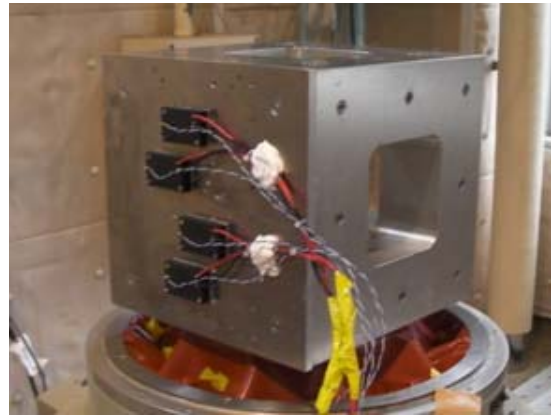

Fig.4.2.2 Y axis

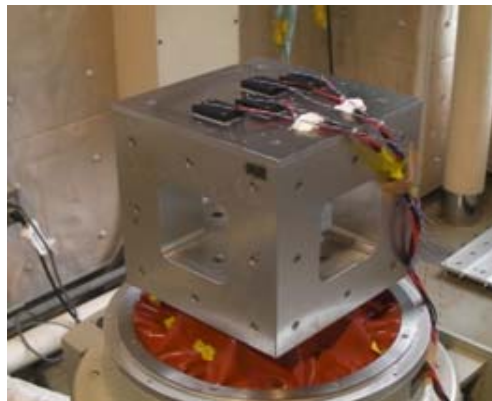

Fig.4.2.3 Z axis

4.2.2 Test result

Table 4.2
Test result

Model	Apparent condition	Output voltage monitoring
DHS50A series	Pass	Pass
DHS100A series	Pass	Pass
DHS200A series	Pass	Pass

No degradation of electric characteristics no marked damage of appearance after test is confirmed. And no interruption of output voltage during and after test is confirmed.

5. External circuit for RIA12 Surge Protection

- The surge protection circuit for Railway application is shown in Fig.5.1.

Fig.5.1
Surge protection
circuit

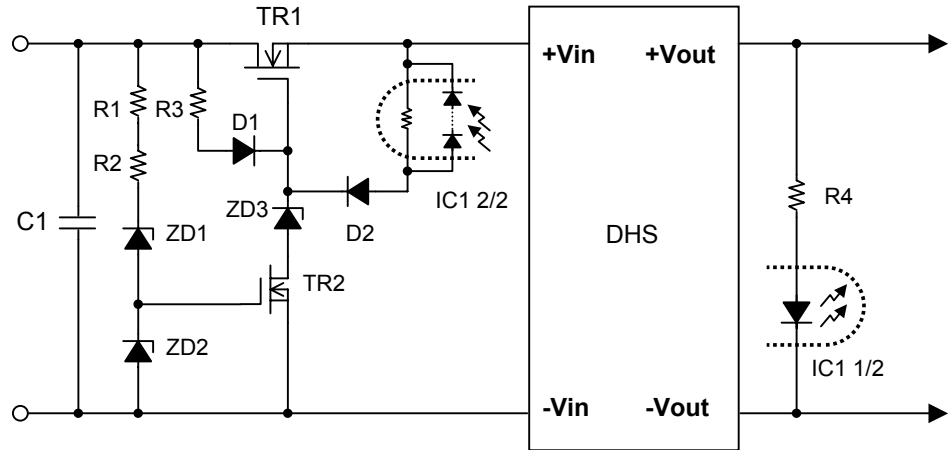
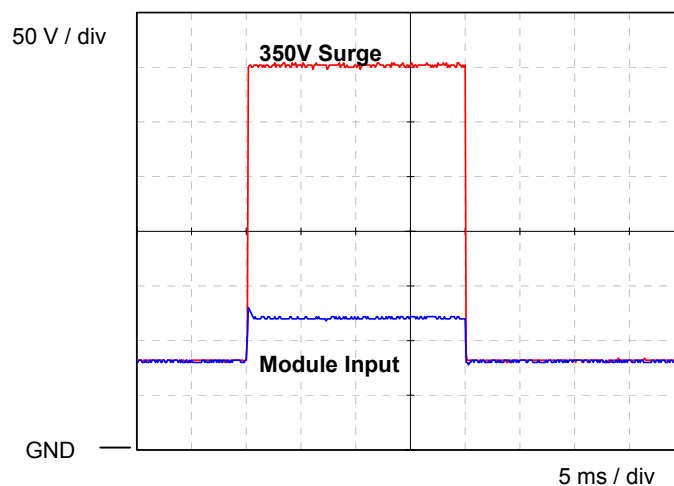

Table 5.1
Example of value

C1	400V, 1 μ F	ZD1	1/2W, 160V
R1	1/4W, 22k Ω	ZD2	1/4W, 10V
R2	1/4W, 22k Ω	ZD3	1/2W, 160V
R3	1/4W, 33k Ω	IC1	TLP591B (TOSHIBA)
D1	1N4148	TR1	IRFP450
D2	1N4148	TR2	IRFD110
R4	1/4W, (Output voltage / 5) k Ω		

Fig.5.2
Clamped surge
voltage



- Input transient surge voltage (20 ms max) is clamped to the module's input range, through the circuit in Fig.5.1.

6. Life cycle by Heat cycle

- Quality design notification. It is necessary to note product lifetime caused by thermal fatigue of solder connection. The thermal fatigue is accelerated by heat cycle (rise/fall in heat). Especially, assumed regular heat cycle need to be minimized rise/fall temperature difference for longer product life time expectancy. please reduce the difference as much as possible when the rise/fall in heat are frequently repeated

Times of ON/OFF is one of generator to make rise/fall temperature difference. Fig. 6.4 is for your design reference which indicating lifetime expectancy against the difference and times of ON/OFF standardized on base plate temperature.

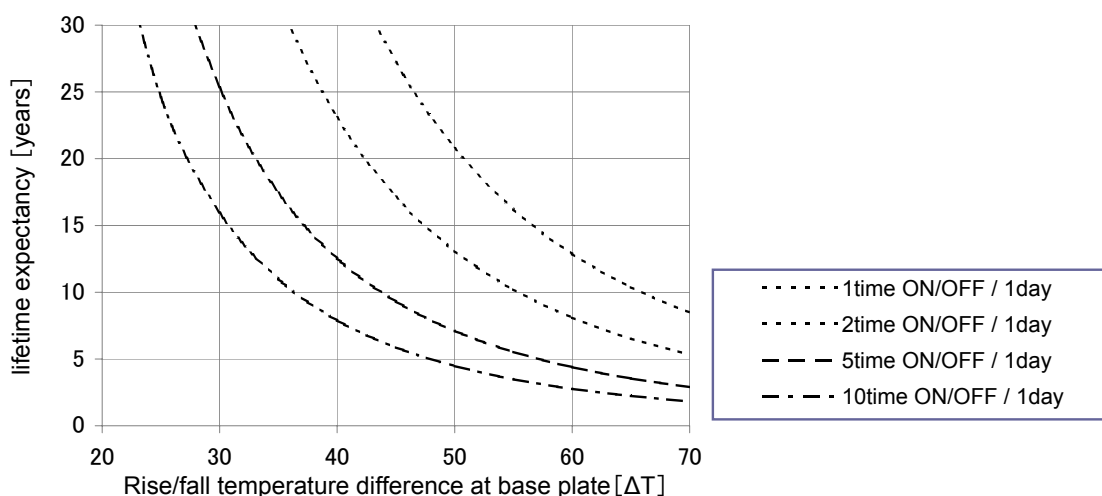

Fig. 6.4 Lifetime expectancy against rise/fall temperature difference

- Fig.6.4 is calculated based on the following conditions.

Acceleration test : Heat cycle test -40°C ~ 125°C 30 minutes, 1200 cycles
 No degradation of electric characteristics is found.

Formula : Modified Coffin-Manson Equation

$$= \left(\frac{f_1}{f_2} \right)^{\frac{1}{3}} \times \left(\frac{\Delta T_2}{\Delta T_1} \right)^2 \times e^{\left(1414 \times \left(\frac{1}{T_{1 \max}} - \frac{1}{T_{2 \max}} \right) \right)} \times n_2$$

- f : Times of ON/OFF / 1day
- ΔT : Base plate temperature difference between Ton and Toff (K)
- Tmax : Maximum temperature of base plate
- n : Count of Heat cycles
- 1, 2 : Subscription to denote Field and Lab conditions, respectively



DHS50A,DHS100A Safety test results

April 16, 2010
OS DESIGN DEPT.

Approved: Tatsuya Mano
Tatsuya Mano

Prepared: Tetsuro Hirata
Tetsuro Hirata

No.	Test item	Test conditions	Conditions of acceptability	Result
1	High temp./overload test	(1) Input Max.voltage, Min.voltage (2) Overload (3) Baseplate temp. 100 (4) Test period 48 hours (5) Testing circuitry Fig.1	(1) Power supply is not failed.	OK
2	Capacitance reduction test	(1) Rated input (DC110V) (2) Rated output (3) Ambient temp. 25±10	(1) No smoke, no fire. (2) No rise of the output voltage.	OK
3	high voltage input test	(1) Input (DC220V) (2) Rated output (3) Ambient temp. : 25±10 (4) Testing circuitry Fig.1	(1) No smoke, no fire.	
4	Low voltage input test	(1) Input Min. regulation voltage (2) Rated output (3) Baseplate temp. 100 (4) Test period 48 hours (5) Testing circuitry Fig.1	(1) Power supply is not failed.	OK
5	Input ON/OFF test	(1) Input : Max.voltage T= 2sec Duty= 50% (2) Output : Rated output (3) Ambient temp. : 25±10 (4) On/off period : 1,000 (5) Test circuit : Fig.1	(1)Power supply is not failed. (2)The surge current of each components should not exceed the rated value.	OK
6	Output ON/OFF test	(1) Rated input (DC110V) (2) Output 0% 100% T= 2sec Duty= 50% (3) Ambient temp. 25±10 (4) On/Off period 1,000 (5) Testing circuitry Fig.1	(1) Power supply is not failed.	OK
7	Output-short start test	(1) Rated input (DC110V) (2) Output Short start (3) Ambient temp. 25±10 (4) Testing circuitry Fig.1	(1) Power supply is not failed.	OK
8	Output short test	(1) Rated input (DC110V) (2) Output Short (3) Ambient temp. 25±10 (4) Test period 48 hours (5) Testing circuitry Fig.1	(1) Power supply is not failed.	OK
9	Withstand voltage test (High-pot test)	(1) Input Not applied. (2) Ambient temp. 25±10 (3) The applied voltage is 1.4 times of specifications.	(1) Insulation breakdown ,flashover or electric arc is not occurred.	OK
10	Isolation resistance test	(1) Input Not applied. (2) Ambient temp. 25±10	(1) When a regulation voltage is applied, isolation resistance is 1.4 times of specifications.	OK
11	Vibration/impact test	Vibrator (1)f=10 ~ 55Hz : 49.0m/s ² (2)3 minutes period (3)60 minutes along X, Y and Z axis Impact (1)196.1m/s ² 11ms (2)Once each X, Y and Z axis	(1) No degradation of electric characteristics after test. (2) No crack at solder joint. (3) No marked damage of appearance.	OK
12	Line Noise Tolerance test	(1) Input (AC90V) (2) Rated Output (3) Ambient temp. 25±10 (4) Test Voltage ±1 kV (5) Pulse width 50 ~ 1000nS (6) Mode Normal and Common (7) Testing circuitry Appendix3 Fig.1	(1) No protection circuit failure. (2) No output voltage drop with control circuit failure. (3) No any other function failure.	OK

ISafety testing circuitry

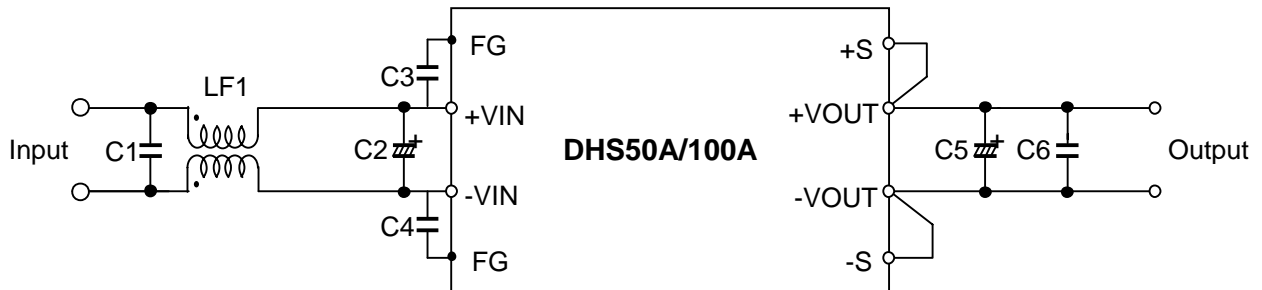

Fig.1 testing circuitry (from No.1 to No.10)

- C1 : 0.1uF 250V Ceramic capacitor
- C2 : 22uF 250V Electric Capacitor
- C3, C4 : 2200pF 250V Ceramic capacitor
- C5 : 2200uF 10V Electric capacitor (DHS50A05/100A05)
: 470uF 35V Electric capacitor(DHS50A12,15/DHS100A12,15)
: 220uF 35V Electric capacitor (DHS50A24/DHS100A24)
- C6 : 10uF 50V Ceramic capacitor(DHS50A05,12,15/DHS100A05,12,15)
: 4.7uF 51V Ceramic capacitor(DHS50A24/DHS100A24)
- LF1 : 1mH 3A Common mode Choke Coil

or equivalent.



DHS200A Safety test results

August 9, 2010
OS DESIGN DEPT.

Approved: Takayuki Fukuda
Takayuki Fukuda

Prepared: Ryosuke Nakao
Ryosuke Nakao

No.	Test item	Test conditions	Conditions of acceptability	Result
1	High temp./overload test	(1) Input Max.voltage, Min.voltage (2) Overload (3) Baseplate temp. 100 (4) Test period 48 hours (5) Testing circuitry Fig.1	(1) Power supply is not failed.	OK
2	Capacitance reduction test	(1) Rated input (DC110V) (2) Rated output (3) Ambient temp. 25 ± 10	(1) No smoke, no fire. (2) No rise of the output voltage.	OK
3	high voltage input test	(1) Input (DC220V) (2) Rated output (3) Ambient temp. : 25 ± 10 (4) Testing circuitry Fig.1	(1) No smoke, no fire.	
4	Low voltage input test	(1) Input Min. regulation voltage (2) Rated output (3) Baseplate temp. 100 (4) Test period 48 hours (5) Testing circuitry Fig.1	(1) Power supply is not failed.	OK
5	Input ON/OFF test	(1) Input : Max.voltage T= 2sec Duty= 50% (2) Output : Rated output (3) Ambient temp. : 25 ± 10 (4) On/off period : 1,000 (5) Test circuit : Fig.1	(1)Power supply is not failed. (2)The surge current of each components should not exceed the rated value.	OK
6	Output ON/OFF test	(1) Rated input (DC110V) (2) Output 0% 100% T= 2sec Duty= 50% (3) Ambient temp. 25 ± 10 (4) On/Off period 1,000 (5) Testing circuitry Fig.1	(1) Power supply is not failed.	OK
7	Output-short start test	(1) Rated input (DC110V) (2) Output Short start (3) Ambient temp. 25 ± 10 (4) Testing circuitry Fig.1	(1) Power supply is not failed.	OK
8	Output short test	(1) Rated input (DC110V) (2) Output Short (3) Ambient temp. 25 ± 10 (4) Test period 48 hours (5) Testing circuitry Fig.1	(1) Power supply is not failed.	OK
9	Withstand voltage test (High-pot test)	(1) Input Not applied. (2) Ambient temp. 25 ± 10 (3) The applied voltage is 1.4 times of specifications.	(1) Insulation breakdown ,flashover or electric arc is not occurred.	OK
10	Isolation resistance test	(1) Input Not applied. (2) Ambient temp. 25 ± 10	(1) When a regulation voltage is applied, isolation resistance is 1.4 times of specifications.	OK
11	Vibration/impact test	Vibration (1)f=10 ~ 55Hz : 49.0m/s ² (2)3 minutes period (3)60 minutes along X, Y and Z axis Impact (1)196.1m/s ² 11ms (2)Once each X, Y and Z axis	(1) No degradation of electric characteristics after test. (2) No crack at solder joint. (3) No marked damage of appearance.	OK
12	Line Noise Tolerance test	(1) Input (AC90V) (2) Rated Output (3) Ambient temp. 25 ± 10 (4) Test Voltage ± 1 kV (5) Pulse width 50 ~ 1000nS (6) Mode Normal and Common (7) Testing circuitry Appendix3 Fig.1	(1) No protection circuit failure. (2) No output voltage drop with control circuit failure. (3) No any other function failure.	OK

Safety testing circuitry

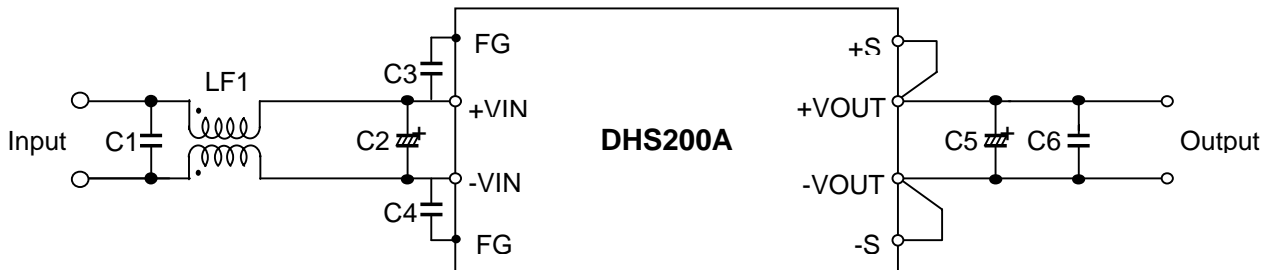

Fig.1 Safety testing circuitry (from No.1 to No.10)

C1	:	0.33 μ F 250V Ceramic capacitor
C2,C3	:	47 μ F Electric capasitor
C3,C4	:	2200pF 250V Ceramic capacitor
C5	:	2200 μ F 10V Electoric capacitot (DHS200A05)
		1000 μ F 25V Electoric capacitot (DHS200A12,15)
		470 μ F 50V Electoric capacitot (DHS200A24)
C6	:	10 μ F 50V Ceramic capacitor (DHS200A05,12,15)
		4.7 μ F 50V Ceramic capacitor (DHS200A24)
LF1	:	3mH 10A Common mode Choke Coil

or equivalent

DHS50A,DHS100A Reliability Test results

 Approved : Tatsuya Mano
 Tatsuya Mano

 Prepared : Tetsuro Hirata
 Tetsuro Hirata

No.	Test Item	Testing conditions	Conditions of acceptability	Number of samples	Number of failures
1	Heat cycle test	(1) -40 ° C ~ 125 ° C 30minutes each (2) 600cycles	(1)No degradation of electric characteristics after test.	5	0
2	High temperature/ High humidity bias test	(1) Ta=85 °C ,RH=85% (2) At rated input (3) Load 0% (4) 1000hours	(1)No degradation of electric characteristics after test.	3	0
3	Vibration test	(1) f=10 ~ 55Hz,49.0m/s ² (5G) (2) 3minutes period (3) 1hour each X,Y and Z axis	(1)No degradation of electric characteristics after test. (2)No crack at solder joint. (3)No marked damage of appearance.	3	0
4	Impact test	(1) 196.1m/s ² (20G),11ms (2) Once each X,Y and Z axis	(1)No degradation of electric characteristics after test. (2)No crack at solder joint. (3)No marked damage of appearance.	3	0
5	Soldering heat test	(1) 260 °C ,15seconds (2) Mounting board : t=1.6mm / FR-4	(1)No crack at solder joint. (2)No marked damage of appearance.	1	0
6	Soldering test	(1) Pre-process Vapor agein(100 °C /100%),1H Flux treatment (2) Soldering 235 ± 5 °C ,2seconds	(1)Over 95% of dipped part is covered with solder.	1	0
7	Pin strength test immunity test	(1) Weight 1 pin : 2kg 2 pin : 4kg (2) Bending angle:90 deg., total 180 deg. (3) 1 cycle	(1)No degraation of electric characteristics after test. (2)No broken or bent pin.	5	0
8	Static electricity immunity test	(1) Applied voltage ± 8kV (2) At rated input and load	(1)No protection circuit fail. (2)No output voltage drop with control circuit fail. (3)No any other function fail.	1	0

DHS200A Reliability Test results

 Approved : Takayuki Fukuda
 Takayuki Fukuda

 Prepared : Ryosuke Nakao
 Ryosuke Nakao

No.	Test Item	Testing conditions	Conditions of acceptability	Number of samples	Number of failures
1	Heat cycle test	(1) -40 ° C 125 ° C 30minutes each (2) 600cycles	(1)No degradation of electric characteristics after test.	9	0
2	High temperature/ High humidity bias test	(1) Ta=85 ,RH=85% (2) At rated input (3) Load 0% (4) 1000hours	(1)No degradation of electric characteristics after test.	6	0
3	Vibration test	(1) f=10 ~ 55Hz,49.0m/s ² (5G) (2) 3minutes period (3) 1hour each X,Y and Z axis	(1)No degradation of electric characteristics after test. (2)No crack at solder joint. (3)No marked damage of appearance.	4	0
4	Impact test	(1) 196.1m/s ² (20G),11ms (2) Once each X,Y and Z axis	(1)No degradation of electric characteristics after test. (2)No crack at solder joint. (3)No marked damage of appearance.	4	0
5	Soldering heat test	(1) 260 ,15seconds (2) Mounting board : t=1.6mm / FR-4	(1)No crack at solder joint. (2)No marked damage of appearance.	1	0
6	Soldering test	(1) Pre-process Vapor agein(100 /100%),1H Flux treatment (2) Soldering 235 ± 5 ,2seconds	(1)Over 95% of dipped part is covered with solder.	1	0
7	Pin strength test immunity test	(1) Weight 1 pin : 2kg 2 pin : 4kg (2) Bending angle:90 deg., total 180 deg. (3) 1 cycle	(1)No degraation of electric characteristics after test. (2)No broken or bent pin.	6	0
8	Static electricity immunity test	(1) Applied voltage ± 8kV (2) At rated input and load	(1)No protection circuit fail. (2)No output voltage drop with control circuit fail. (3)No any other function fail.	2	0

DHS50A,DHS100A EMI / EMS Test result

 Approved : Tatsuya Mano
 Tatsuya Mano

 Prepared : Tetsuro Hirata
 Tetsuro Hirata

No.	Test item	Conditions	Conditions of Acceptability	Result
1	Line conduction	(1) Rated input(DC110V/AC90V) (2) Rated load (3) Ambient temp. 25 ± 10 (4) Testing circuitry Fig.1	(1)Meets the undermentioned standard. FCC Part15 classA , VCCI classA CISPR11 classA , EN55011-A	OK
2	Radiated emission	(1) Rated input(DC110V/AC90V) (2) Rated load (3) Ambient temp. 25 ± 10 (4) Testing circuitry Fig.1	(1)Meets the undermentioned standard. FCC Part15 classA , VCCI classA CISPR11 classA , EN55011-A	OK
3	Static electricity immunity test (EN61000-4-2)	(1) Rated input(DC110V/AC90V) (2) Rated load (3) Ambient temp. 25 ± 10 (4) Contact discharge voltage 8[kV] (EN61000-4-2 Level 4) (5) Testing circuitry Fig.1	(1)No protection circuit failure. (2)No output voltage drop with control circuit failure. (3)No any other function failure	OK
4	Radiated, radio-frequency, electromagnetic field immunity test (EN61000-4-3)	(1) Rated input(DC110V/AC90V) (2) Rated load (3) Ambient temp. 25 ± 10 (4)Testing field strength 10[V/m] (EN61000-4-3 Level 3) (5) Testing circuitry Fig.1	(1)No protection circuit failure. (2)No output voltage drop with control circuit failure. (3)No any other function failure	OK
5	Electrical fast transient/ burst immunity test (EN61000-4-4)	(1) Rated input(DC110V/AC90V) (2) Rated load (3) Ambient temp. 25 ± 10 (4) Test peak voltage 4[kV] (IEC61000-4-4 Level 4) (5) Testing circuitry Fig.1	(1)No protection circuit failure. (2)No output voltage drop with control circuit failure. (3)No any other function failure	OK
6	Surge immunity test (EN61000-4-5)	(1) Rated input(DC110V/AC90V) (2) Rated load (3) Ambient temp. 25 ± 10 (4) Test voltage Line to line 2[kV] (Level 3) Line to earth 4[kV] (Level 4) (5) Testing circuitry Fig.2	(1)The power supply is not stop (2)Circuit does not malfunction. (3)No abnormality of the insulation destruction etc. (4)Parts are no damaged.	OK
7	Immunity to conducted disturbances, induced by radio-frequency fields (EN61000-4-6)	(1) Rated input(DC110V/AC90V) (2) Rated load (3) Ambient temp. 25 ± 10 (4) Voltage level (e.m.f.) 10[V] (Level 3) (5) Testing circuitry Fig.1	(1)No protection circuit failure. (2)No output voltage drop with control circuit failure. (3)No any other function failure	OK

●EMI/EMS testing circuitry

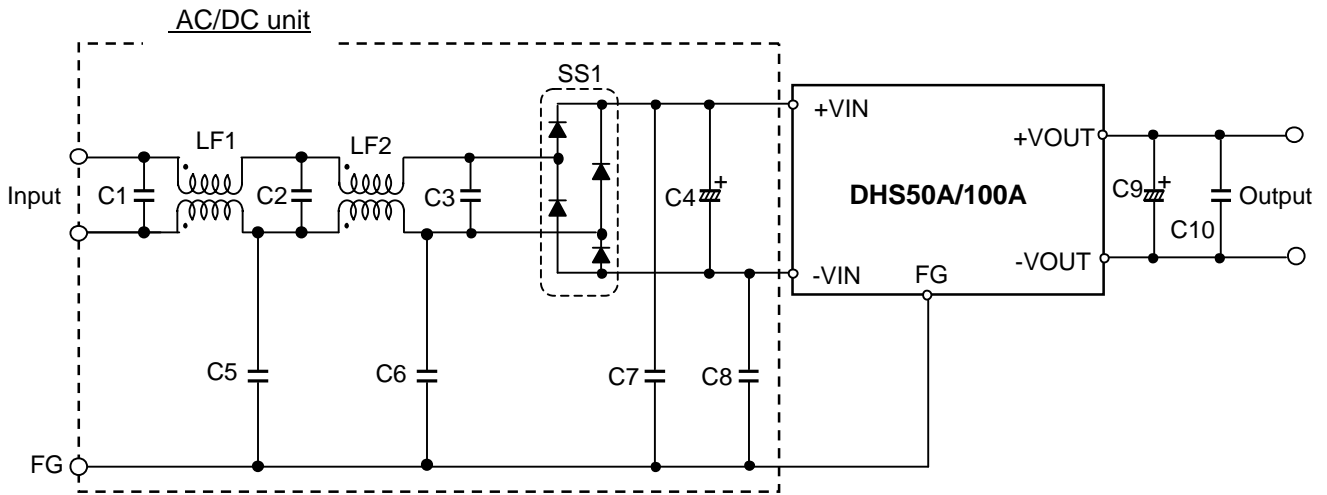

Fig.1 testing circuitry (from No.1 to No.5, No.7)

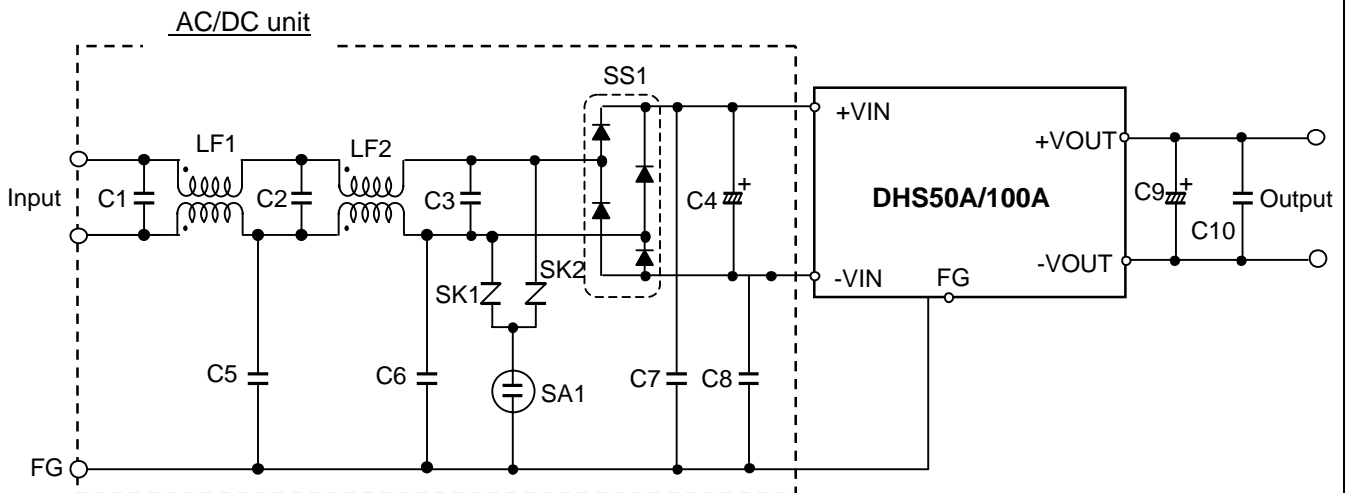
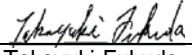

Fig.2 testing circuitry (No.6)

- C1, C2, C3 : 0.1uF 250V Ceramic capacitor
 C4 : 270uF 250V Electric capacitor
 C5, C6, C7, C8 : 2200pF 250V Ceramic capacitor
 LF1 : 2mH 5A Common mode Choke Coil
 LF2 : 2mH 5A Common mode Choke Coil
 SA1 : DSA302 (MITSUBISHI MATERIALS CORP.)
 SK1, SK2 : ENE471D-10A(FUJI ELECTRIC CO., LTD)
 SS1 : 4A 600V Bridge diode
- C9 : 2200uF 10V Electric capacitor (DHS50A05/DHS100A05)
 : 470uF 35V Electric capacitor(DHS50A12,15/DHS100A12,15)
 : 220uF 35V Electric capacitor (DHS50A24/DHS100A24)
 C10 : 10uF 50V Ceramic capacitor(DHS50A05,12,15/DHS100A05,12,15)
 : 4.7uF 50V Ceramic capacitor(DHS50A24/DHS100A24)

or equivalent.

DHS200A EMI / EMS Test result

 Approved : 
 Takayuki Fukuda

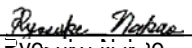
 Prepared : 
 RYOSUKE NISHIO

No.	Test item	Conditions	Conditions of Acceptability	Result
1	Line conduction	(1) Rated input(DC110V/AC90V) (2) Rated load (3) Ambient temp. 25 ± 10 (4) Testing circuitry Fig.1	(1)Meets the undermentioned standard. FCC Part15 classA , VCCI classA CISPR11 classA , EN55011-A	OK
2	Radiated emission	(1) Rated input(DC110V/AC90V) (2) Rated load (3) Ambient temp. 25 ± 10 (4) Testing circuitry Fig.1	(1)Meets the undermentioned standard. FCC Part15 classA , VCCI classA CISPR11 classA , EN55011-A	OK
3	Static electricity immunity test (EN61000-4-2)	(1) Rated input(DC110V/AC90V) (2) Rated load (3) Ambient temp. 25 ± 10 (4) Contact discharge voltage 8[kV] (EN61000-4-2 Level 4) (5) Testing circuitry Fig.1	(1)No protection circuit failure. (2)No output voltage drop with control circuit failure. (3)No any other function failure	OK
4	Radiated, radio-frequency, electromagnetic field immunity test (EN61000-4-3)	(1) Rated input(DC110V/AC90V) (2) Rated load (3) Ambient temp. 25 ± 10 (4)Testing field strength 10[V/m] (EN61000-4-3 Level 3) (5) Testing circuitry Fig.1	(1)No protection circuit failure. (2)No output voltage drop with control circuit failure. (3)No any other function failure	OK
5	Electrical fast transient/ burst immunity test (EN61000-4-4)	(1) Rated input(DC110V/AC90V) (2) Rated load (3) Ambient temp. 25 ± 10 (4) Test peak voltage 4[kV] (IEC61000-4-4 Level 4) (5) Testing circuitry Fig.1	(1)No protection circuit failure. (2)No output voltage drop with control circuit failure. (3)No any other function failure	OK
6	Surge immunity test (EN61000-4-5)	(1) Rated input(DC110V/AC90V) (2) Rated load (3) Ambient temp. 25 ± 10 (4) Test voltage Line to line 2[kV] (Level 3) Line to earth 4[kV] (Level 4) (5) Testing circuitry Fig.2	(1)The power supply is not stop (2)Circuit does not malfunction. (3)No abnormality of the insulation destruction etc. (4)Parts are no damaged.	OK
7	Immunity to conducted disturbances, induced by radio-frequency fields (EN61000-4-6)	(1) Rated input(DC110V/AC90V) (2) Rated load (3) Ambient temp. 25 ± 10 (4) Voltage level (e.m.f.) 10[V] (Level 3) (5) Testing circuitry Fig.1	(1)No protection circuit failure. (2)No output voltage drop with control circuit failure. (3)No any other function failure	OK

●EMI/EMS testing circuitry

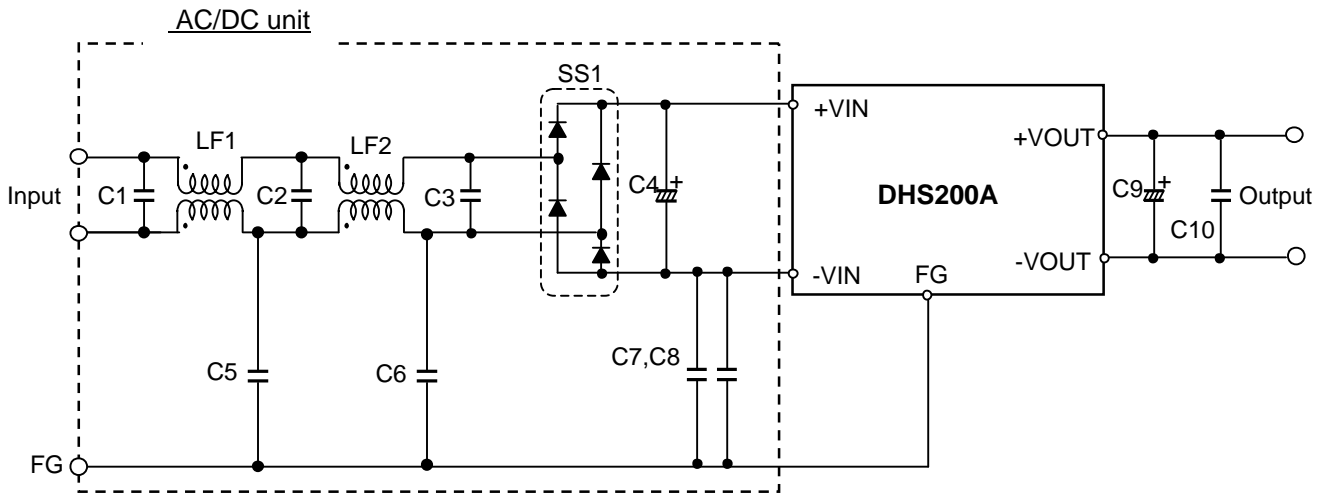

Fig.1 testing circuitry (from No.1 to No.5, No.7)

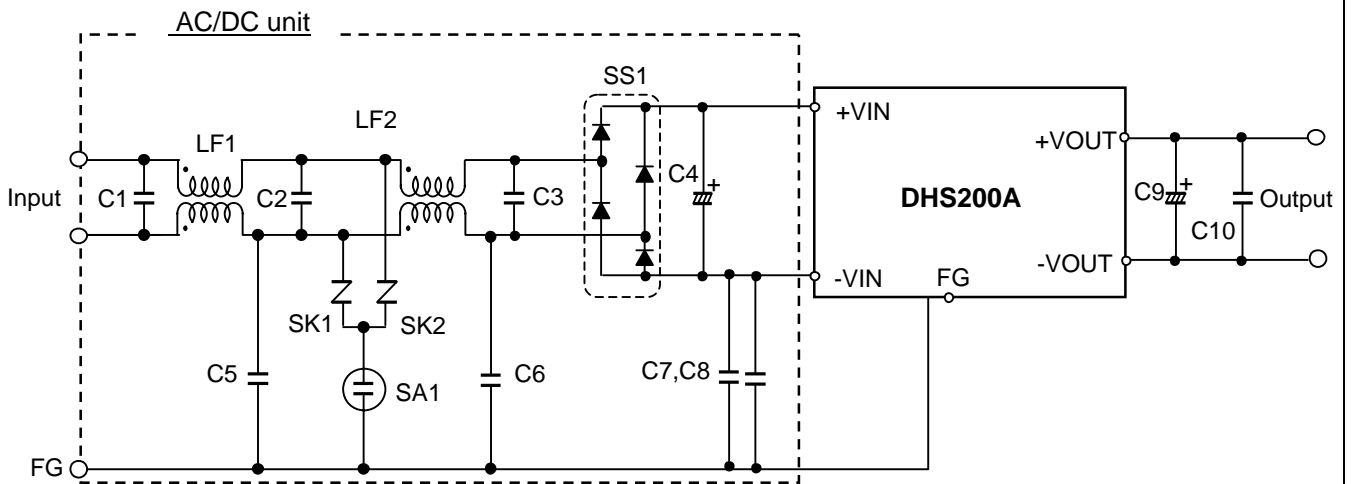

Fig.2 testing circuitry (No.6)

C1	: 0.33 μ F 250V Ceramic capacitor
C2, C3	: 0.1 μ F 250V Ceramic capacitor
C4	: 470 μ F 250V Electric capacitor
C5, C6, C7, C8	: 2200 μ F 250V Ceramic capacitor
LF1	: 3mH 10A Common mode Choke Coil
LF2	: 3mH 10A Common mode Choke Coil
SA1	: DSA-302MA(MITSUBISHI MATERIALS COAP.)
SK1, SK2	: ENE471D-10A(FUJI ELECTRIC CO., LTD)
SS1	: 10A 600V Bridge diode
C9	: 2200 μ F 10V Electric capacitor (DHS200A05) : 1000 μ F 25V Electric capacitor(DHS200A12,15) : 470 μ F 35V Electric capacitor (DHS200A24)
C10	: 10 μ F 50V Ceramic capacitor(DHS200A05,12,15) 4.7 μ F 50V Ceramic capacitor(DHS200A24)

or equivalent.